

HX1050-S CAN Bus Transceiver

General Description

The HX1050-S serves as the interface between the Controller Area Network (CAN) protocol controller and the physical bus. It is designed for high-speed applications, specifically in passenger cars, supporting speeds of up to 1 MBaud. This device enables differential transmission to the bus and differential reception to the CAN controller.

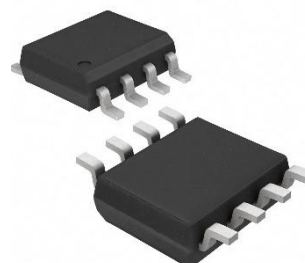

SOP-8

Features

- High speed (up to 1 MBaud)
- Silent mode
- Transceiver in unpowered state disengages from the bus (zero load)
- Differential receiver with high common-mode range for ElectroMagnetic Immunity (EMI)
- At least 110 nodes can be connected
- Transmit Data (TXD) dominant time-out function
- Bus pins protected against transients in automotive environments
- Thermally protected

Applications

- Industrial control automation
- Automotive electronics
- Point-to-point and point-to-multipoint communications
- Intelligent instrumentation
- Building automation systems
- Security systems
- Road traffic control automation
- Level converters

PIN CONFIGURATIONS AND FUNCTIONS

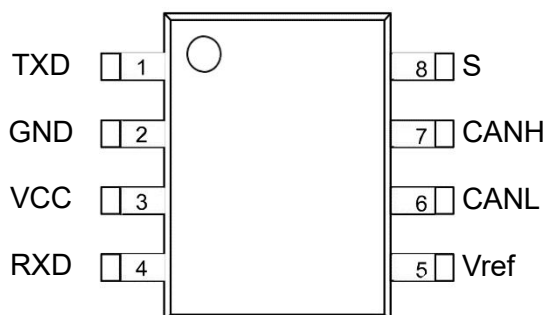

Pin Descriptio		
Pin	Name	Description
1	TXD	transmit data input
2	GND	ground supply
3	VCC	supply voltage
4	RXD	receive dataoutput;readsoutdata from the bus lines
5	Vref	Reference Voltage Output
6	CANL	LOW-level CAN bus line
7	CANH	HIGH-level CAN busline
8	S	High speed and mute mode selection, low level for high speed

Absolute Maximum Rating					
SYMBOL	PARAMETER	MIN	MAX	UNIT	
VCC	Supply voltage range	-0.3	+6	V	
TXD, RXD, STB, Vref	MCU Side Port	-0.3	VCC+0.3	V	
CANL, CANH	Bus-side port voltage	-60	+60	V	
Vtr	Pin 6, 7 Transient Voltage	-200	+200	V	
	storage temperature	-55	150	°C	
	ambient temperature	-40	125	°C	
	Welding temperature range	-	300	°C	

SPECIFICATIONS

(VCC=5V±10%, Temp=TMIN~TMAX, typical values at VCC=+5V, Temp=25°C, unless otherwise noted)

Bus Transmitter DC Character						
SYMBOL	PARAMETER	TESTCONDITIONS	MIN	MAX	UNIT	SYMB
VOH(D)	CANH output voltage (dominant)	VI=0V, STB=0V, RL=60Ω F1、 2	2.9	3.4	4.5	
VOL(D)	CANL output voltage (dominant)		0.8		1.5	
VO(R)	Bus Output Differential Voltage(implicit)	VI=3V, STB=0V, RL=60Ω, F1、 2	2	2.5	3	V
VOD(D)	Bus Output Differential Voltage (dominant)	VI=0V, STB=0V, RL=60Ω, F1、 2	1.5		3	V
VOD(R)	Bus Output Differential Voltage (implicit)	VI=3V, S=0V, F1、 2	-0.012		0.012	V
		VI=3V, STB=0V, NO LOAD	-0.5		0.05	V
Vdom(TX)sym	dominant output voltage symmetry	Vdom(TX)sym=VCC- VCANH	-400		400	mV
VTXsym	Output Voltage Symmetry	VTXsym= VCANH + VCANL	0.9Vc		1.1Vc	V
VOC	Common mode output voltage	STB=0V, F 8	2	2.5	3	V
△VOC	Explicit and implicit common mode output voltage difference			30		mV
IOS	Short-circuit output current	CANH=-12V,	-105	-72		mA
VIL	Low Level Input			0.36	1	
Ios Io(R)	Short-circuit output current Hidden output current	CANH=-12V, CANL=open, F 11	-1	0.5		
		CANH=12V, CANL=open, F 11		71	105	
		-27V<CANH<32V 0<VCC<5.25V	-2.0		2.5	mA
Bus Transmitter Switch Characteristic						
tPLH	Transmission delay (low to high)	STB=0V, F 4	25	65	120	ns
tPHL	Transmission delay (high to low)		25	45	90	ns
tr	Differential output rise delay time			25		ns
tf	Differential output fall delay time			50		ns
tEN	Enable time from listen mode to dominant	F 7			1	μs
tdom	Explicit timeout	F 10	300	450	700	μs
tBUS	Bus wake-up time		0.7		5	μs

Bus Receiver DC Paramete						
SYMBOL	PARAMETER	TESTCONDITIONS	MIN	MAX	UNIT	SYMBO
	Positive Input Threshold	S=0V		800	900	mV
V _{IT-}	Negative Input Threshold		500	650		
V _{HYS}	Comparator Threshold Hysteresis		100	125		
V _{OH}	High Level Output Voltage	IO=-2mA	4	4.6		V
V _{OL}	Low Level Output Voltage	IO=2mA		0.2	0.4	V
I _(OFF)	Bus input current at power down	CANH or CANL=5V, Other pin=0V		165	125	μA
C _I	CANH, CANL input capacitance to			13		pF
C _{ID}	CANH, CANL Differential Input			5		pF
R _{IN}	CANH, CANL Input Resistance	TXD=3V, STB=0V	15	30	40	KΩ
R _{ID}	CANH, CANL Differential Input		30		80	KΩ
R _I match	RI(CANH), RIN(CANL) mismatches	CANH=CANL	-3%		3%	
V _{COM}	Common mode voltage range		-12		12	V
Bus Receiver Switching Characteris						
t _{PLH}	Propagation delay (low to high)	STB=0V or VCC	60	100	130	ns
t _{PHL}	Propagation delay (high to low)		45	70	90	ns
t _r	RXD signal rise time			8		ns
t _f	RXD signal fall time			8		ns
Device Switching Character						
T _d (LOOP1)	Loop delay 1, driver input to receiver output, implicit to explicit	STB=0V	90		190	ns
T _d (LOOP2)	Loop Delay 2, Driver Input to Receiver Output, Explicit to Implicit		90		190	ns
Over-temperature protectio						
T _j (sd)	Over temperature shutdown		155	165	180	°C
TXD Pin Characteristi						
I _{IH} (TXD)	TXD port high level input current	V _I =VCC	-2		2	μA
I _{IL} (TXD)	TXD Port Low Level Input Current	V _I =0	-50		-10	μA
I _O (off)	Current in TXD when VCC=0V	VCC=0V.			1	μA
V _{IH}	Input High LowerLimit		2		VCC+0.	V
V _{IL}	Input Low Limit		-0.3		0.8	V
TXD _O	TXD Port Dangle Voltage			H		logic
Vref pin reference voltage output						
V _{ref}	Reference Output Voltage	-50uA<I _o <50uA	0.4V _{CC}		0.6V _{CC}	V
Power consumption characteristic						
ICC	Silent Mode Power Consumption	S=VCC, VI=VCC		6	10	μA
	Dominant power consumption	V _I =0V, S=0V LOAD=60Ω		50	70	mA
	Implicit power consumption	V _I =VCC, S=0V NO LOAD		6	10	mA

Menu (1)H=high; L=low; X=no care

Table 1 CAN Transceiver Truth

VCC	TXD(1)	STB(1)	CANH ⁽¹⁾	CANL ⁽¹⁾	BUS STATE	RXD(1)
4.5V~5.5V	L	L(or float)	H	L	dominant	L
4.5V~5.5V	H (or float)	X	0.5VCC	0.5VCC	implicit	H
4.5V~5.5V	X	H	0.5VCC	0.5VCC	implicit	H
0<VCC<4.5V	X	X	0V<VCANH<VCC	0V<VCANL<VCC	implicit	X

Table 2 Driver Function

INPUTS		OUTPUTS		Bus State
TXD(1)	STB(1)	CANH ⁽¹⁾	CANL ⁽¹⁾	
L	L(or float)	H	L	Dominate(dominant)
H (or floa)	X	Z	Z	Recessive(implicit)
X	H	Z	Z	Recessive(implicit)

Table 3 Receiver Functio

VID=CANH-CANL	RXD(1)	Bus State ⁽¹⁾
VID≥0.9V	L	Dominate(dominant)
0.5<VID<0.9V		
VID≤0.5V	H	Recessive (implicit)
Open	H	Recessive (implicit)

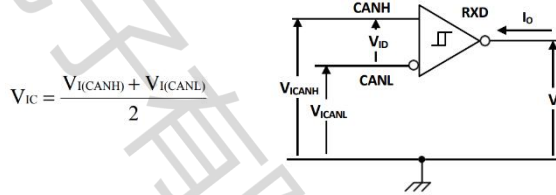
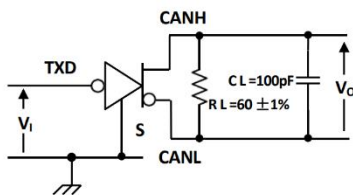

Receiver Voltage and Current Definitions

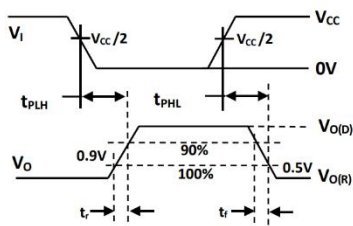

Driver Test Circuit and Voltage Waveforms

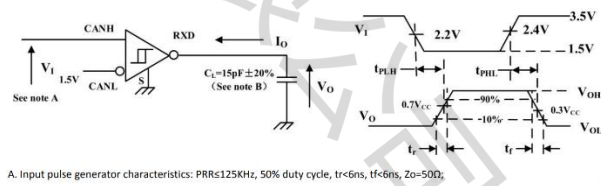

A. Input pulse generator characteristics: PRR≤125KHz, 50% duty cycle, tr<6ns, tf<6ns, Z0=50Ω;
B. CL includes instrumentation and fixed capacitance within 20% error;

Receiver test circuit and voltage wave

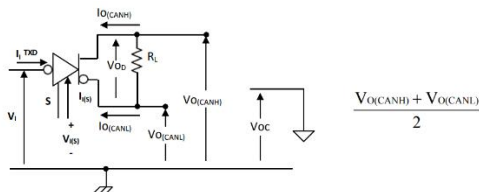

Driver Voltage, Current Test Definition

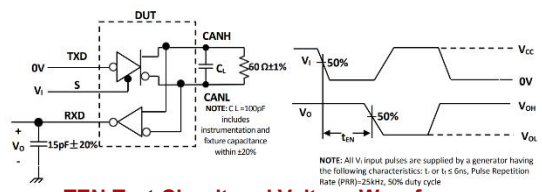

TEN Test Circuit and Voltage Waveforms

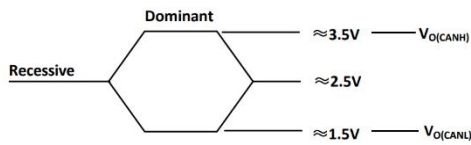

Bus Logic Voltage Definit

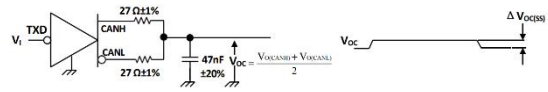

Note: Vi from 0~VCC, input pulse generator characteristics: PRR≤125KHz, 50% duty cycle, tr<6ns, tf<6ns, Z0=50Ω.

Common Mode Output Voltage Test and Wave

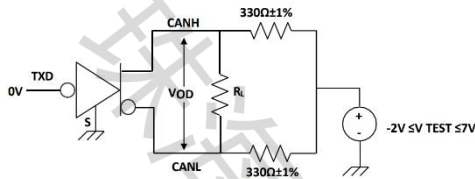

Driver VOD Test Circuit

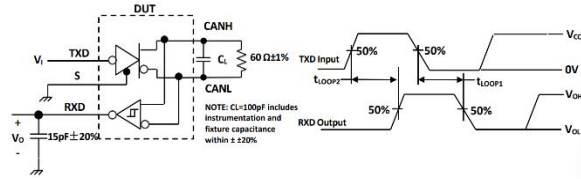

t(LOOP) Test Circuit and Waveform

DESCRIPTION

The HX1050-S is a chip that serves as an interface between a CAN protocol controller and the physical bus in various applications such as trucks, buses, cars, and industrial control systems. It is designed to comply with the ISO 11898 standard and can achieve a speed of 1Mbps.

One of the key features of the HX1050-S is its short circuit protection, which prevents the driver circuit from short-circuiting to positive and negative supply voltages. This protection mechanism limits the current flow and safeguards the driver stage from damage.

Additionally, the HX1050-S incorporates an over-temperature protection function. When triggered, this function reduces the current in the driver stage, which helps to lower the chip's temperature. Meanwhile, the rest of the chip continues to function normally.

Another important feature is the built-in TXD dominant timeout timer circuit. This circuit prevents the bus line from being permanently driven to a dominant state, which could block all network communications, in case of a hardware or software failure that keeps the TXD pin low for an extended period. The timer is triggered by a negative edge on the TXD pin, and if the low level duration exceeds the internal timer value, the transmitter is disabled, causing the bus to enter a recessive state. The timer can be reset by a positive edge on the TXD pin.

Packing

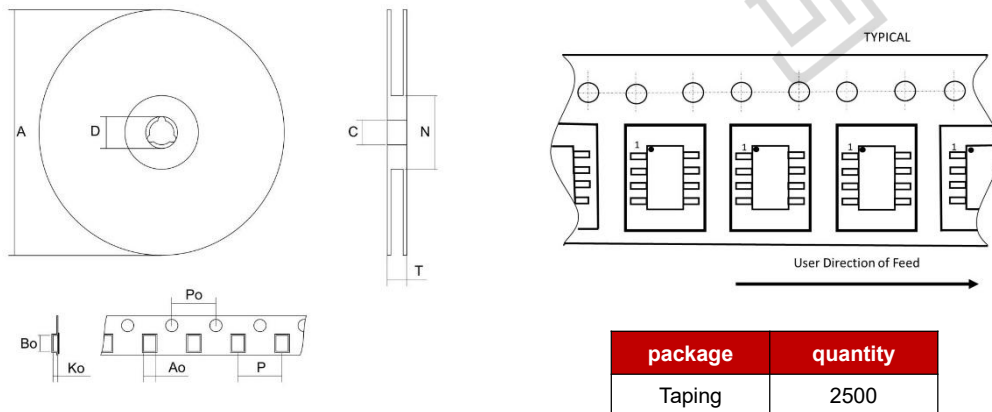

Disclaimer

All products due to improve reliability, function or design or for other reasons, product specifications and data are subject to change without notice.

Zhuhai Haixin Electronics Co., Ltd., branches, agents, employees, and all persons acting on its or their representatives (collectively, the "zhuhai Haixindianzi"), assumes no responsibility for any errors, inaccuracies or incomplete data contained in the table or any other any disclosure of any information related to the product. (www.haixindianzi.com)

Zhuhai Haixin makes no guarantee, representation or warranty on the product for any particular purpose of any goods or continuous production. To the maximum extent permitted by applicable law on Zhuhai Haixin relinquished: (1) any application and all liability arising out of or use of any products; (2) any and all liability, including but not limited to special, consequential damages or incidental ; (3) any and all implied warranties, including a particular purpose, non-infringement and merchantability guarantee.

Statement on certain types of applications are based on knowledge of the product is often used in a typical application of the general product Haixin Zhuhai demand that the Zhuhai Haixin of. Statement on whether the product is suitable for a particular application is non-binding. It is the customer's responsibility to verify specific product features in the products described in the specification is appropriate for use in a particular application. Parameter data sheets and technical specifications can be provided may vary depending on the application and performance over time. All operating parameters, including typical parameters must be made by customer's technical experts validated for each customer application. Product specifications do not expand or modify Zhuhai Haixin purchasing terms and conditions, including but not limited to warranty herein.

Unless expressly stated in writing, Zhuhai Haixin products are not intended for use in medical, life saving, or life sustaining applications or any other application. Wherein Haixin product failure could lead to personal injury or death, use or sale of products used in Zhuhai Haixin such applications using client did not express their own risk. Contact your authorized Zhuhai Haixin people who are related to product design applications and other terms and conditions in writing.

The information provided in this document and the company's products without a license, express or implied, by estoppel or otherwise, to any intellectual property rights granted to the Haixin act or document. Product names and trademarks referred to herein are trademarks of their respective representatives will be all.

X-ON Electronics

Largest Supplier of Electrical and Electronic Components

Click to view similar products for [CAN Interface IC category](#):

Click to view products by [ZHHXDZ manufacturer](#):

Other Similar products are found below :

[PCA82C250T/N4](#) [UJA1169TK/3Z](#) [TLE7251VLE](#) [UM3608QA](#) [TJA1055T/3/1](#) [TJA1044BT/0Z](#) [LTC2875IDD#TRPBF](#) [TLE9251VLE](#)
[TLE9250VLE](#) [ATA6563-GAQW1](#) [MCP251863T-E/SS](#) [ATA6570-GNQW1](#) [UJA1169TK/3](#) [TJA1448BTK/0Z](#) [UJA1169ATK/X/FZ](#)
[TJA1442ATK/0Z](#) [UJA1169TK/F](#) [TJR1443AT/0Z](#) [UJA1169TK/X/FZ](#) [TJA1442BT/0Z](#) [TJA1152BT/0Z](#) [TJA1441BTK/0Z](#)
[TCAN1463DMTRQ1](#) [TCAN1057AVDDFRQ1](#) [TCAN1462VDRBRQ1](#) [TCAN1043ADMTRQ1](#) [TCAN1043ADYYRQ1](#) [TJA1042CT/0Z](#)
[TCAN1057AEVDRQ1](#) [TCAN1043ADRQ1](#) [TLE9252VSK](#) [TLE9250XSJ](#) [CA-IF1042LS-Q1](#) [SN65HVD1050DR-JSM](#) [MCP2562T-E/MFVAO](#)
[TJA1050T-JSM](#) [SIT1042AQTK](#) [TJA1040T-JSM](#) [SSIT1050T](#) [SIT1051ATK/3](#) [TJA1051AT/0Z](#) [SN65HVD1040DR-JSM](#) [SSIT1040T](#) [CA-](#)
[IF1042LVS-Q1](#) [SIT3232EEWE](#) [HGA1042M-3/TR](#) [BIN1051S-C](#) [TLE9471ES V33](#) [CA-IF1044D-Q1](#) [TJA1044VTKZ](#)