

HX4425-S/HX4425-P

3A Dual High-Speed Power MOSFET Driver

General Description

The HX4423/4424/4425 series is a highly reliable BiCMOS/DMOS buffer/driver/MOSFET driver, providing higher output current versions of HX4426/4427/4428 with improved features. These families are pin compatible, and the HX4423/4424/4425 drivers are specifically designed for use in more demanding electrical environments, providing reliable service under any conditions within the rated power and voltage range. They are capable of withstanding noise spikes of up to 5V on the ground pin, regardless of polarity. Compared to other CMOS or bipolar drivers, the HX4423/4424/4425 drivers are easier to use, more flexible to operate, and more forgiving. Their BiCMOS/DMOS structures consume minimal power and provide stable voltage fluctuations.

The HX4423/4424/4425 driver is primarily designed to drive power MOSFETs, and it is ideal for driving other loads such as capacitors, resistors, or inductors that require low impedance, peak current, and fast switching times. It can be used with heavy-duty clock lines, coaxial cables, or piezoelectric transducers. The only limitation is that the total power dissipated in the driver must be kept within the maximum power dissipation limit of the package.

For high power and narrow pulse applications, see the HX4123/4124/4125 series.

Features

- High Peak Output Current: 3A
- Wide Input Supply Voltage Operating Range: - 4.5V to 18V
- High Capacitive Load Drive Capability: - 1800 pF in 25 ns
- Short Delay Times: <40 ns (typ)
- Matched Rise/Fall Times
- Low Supply Current
 - With Logic '1' Input – 3.5 mA (Max)
 - With Logic '0' Input – 350 μ A (Max)
- Low Output Impedance: 3.5 Ω (typ)0
- Latch-Up Protected: Will Withstand 1.5A Reverse Current
- Logic Input Will Withstand Negative Swing Up To 5V
- ESD Protected: 4 kV
- Available in Green SOP8, DIP8 and DFN8 Packages

Applications

- Switch Mode Power Supplies
- Pulse Transformer Drive
- Line Drivers

Pin Configuration and Functions

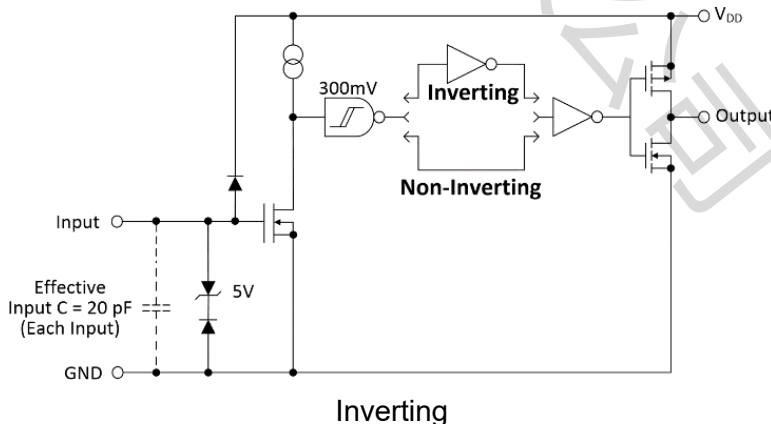

Functional Block Diagram

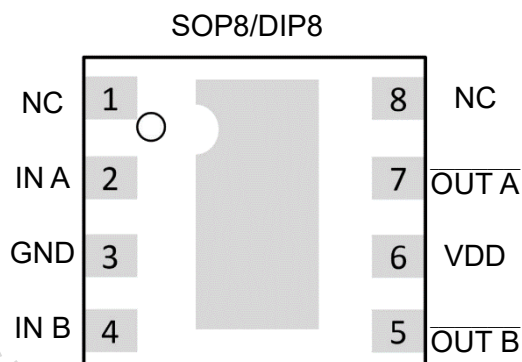

Outputs out of phase with input

Pin Diagram

Function Tab			
INA	INB	OUT A	OUT B
L	L	H	H
L	H	H	L
H	L	L	H
H	H	L	L

Pin Descriptio		
Pin	Name	Description
1	NC	No connection
2	IN A	Input A
3	GND	Ground
4	In B	Input B
5	OUT B	Output of Channel B
6	VDD	Power Supply
7	OUT A	Output of Channel A
8	NC	No connection
-	PAD	Exposed Metal Pad of DFN package

Inputs A and B

MOSFET driver inputs A and B are high-impedance, TTL/CMOS compatible inputs. These inputs also have 300mV of hysteresis between the high and low thresholds that prevents output glitching even when the rise and fall time of the input signal is very slow.

Ground (GND)

Ground is the device return pin. The Ground pin(s) should have a low-impedance connection to the bias supply source return. High peak current flows out the Ground pin(s) when the capacitive load is being discharged.

Output A and B

MOSFET driver outputs A and B are low-impedance, CMOS push-pull style outputs. The pull-down and pullup devices are of equal strength, making the rise and fall times equivalent. Output A/B is held LOW if Input is unbiased or floating.

Supply Input (VDD)

The VDD input is the bias supply for the MOSFET driver and is rated for 4.5V to 25V with respect to the Ground pin. The VDD input should be bypassed with local ceramic capacitors. The value of these capacitors should be chosen based on the capacitive load that is being driven. A value of 1.0 μ F is suggested.

Exposed Metal Pad

The exposed metal pad of the DFN-S package is not internally connected to any potential. Therefore, this pad can be connected to a ground plane or other copper plane on a Printed Circuit Board (PCB), to aid in heat removal from the package.

Product Specification

Absolute Maximum Ratings ⁽¹⁾			
Parameter	Min	Max	Unit
DC supply voltage Vs		26	V
Operating junction temperature	-40	+125	°C
Storage temperature	-55	+150	°C
Maximum input voltage	GND-5	VDD+0.3	V

(1) Stresses exceeding the absolute maximum ratings may damage the device. The device may not function or be operable above the recommended operating conditions and stressing the parts to these levels is not recommended. In addition, extended exposure to stresses above the recommended operating conditions may affect device reliability. The absolute maximum ratings are stress ratings only.

Thermal Data		
Parameter	Rating	Unit
Package Thermal Resistance	155(SOP8)	°C/W
	125(DIP8)	
	118(FDN8,2x2)	

Recommended Operating Conditions		
Parameter	Rating	Unit
DC Supply Voltage	4.5V ~ 25V	V
Operating ambient temperature	-40 to +125	°C

Electrical Characteristics(Typical values are tested at TA=25 oC, VDD=18V)

Parameter	Symbol	Conditions	Min.	Typ.	Max.	Unit
INPUT						
Input Signal High Threshold	V _{IH}		1.6			V
Input Signal Low Threshold	V _{IL}				0.7	V
Input Signal Hysteresis	V _{HYS}			0.3		V
Input Current	I _{IN}	0V ≤ V _{IN} ≤ V _{DD}			±1	μA
OUTPUT						
High Output Voltage V _{OH}	V _{OH}	DC Test	V _{DD} -			V
Low Output Voltage	V _{OL}	DC Test			0.025	V
Pull-Up Resistance	R _{OH}	Source Current = 10mA		1.6		Ω
Pull-Down Resistance	R _{OL}	Sink Current = -10mA		1.5		Ω
Peak Output Current	I _{PK}	10V ≤ V _{DD} ≤ 18V		4.0		A
POWER SUPPLY						
Power Supply Current	I _{CC}	V _{INA} =V _{VINB} =3V		0.9		mA
		V _{INA} =V _{VINB} =0V		0.5		
Operating Voltage Range	V _{DD}		4.5		25	V
Under-Voltage Lockout ON				3.7	4.1	V
Under-Voltage Lockout				0.5		V
SWITCHING CHARACTERISTICS						
Rise Time	t _R	C _L =1800pF,		12		ns
Fall Time	t _F	C _L =1800pF,		12		ns
Turn-On Delay Time	t _{D1}	Non-inverting Input		36		ns
		Inverting Input		35		ns
Turn-On Delay Time	t _{D2}	Non-inverting Input		36		ns
		Inverting Input		35		ns
OVER-TEMPERATURE PROTECTION						
Thermal Shutdown Threshold				150		°C
Thermal Shutdown Threshold				25		°C

Application Informa

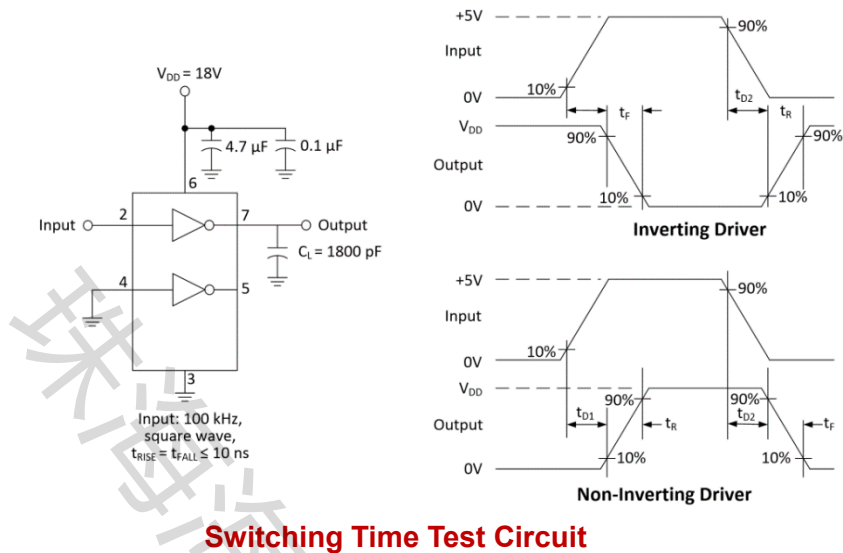

Switching Time Test Circuit

Package Information

SOP8 (Package Outline Dimensions)

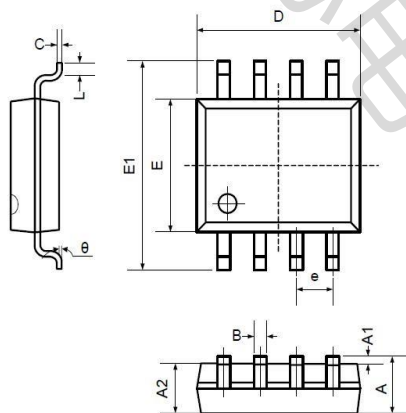

Symbol	Dimensions In Millimeters		Dimensions In Inches	
	Min	Max	Min	Max
A	1.350	1.750	0.053	0.069
A1	0.100	0.250	0.004	0.010
A2	1.350	1.550	0.053	0.061
B	0.330	0.510	0.013	0.020
C	0.190	0.250	0.007	0.010
D	4.780	5.000	0.188	0.197
E	3.800	4.000	0.150	0.157
E1	5.800	6.300	0.228	0.248
e	1.270TYP		0.050TYP	
L	0.400	1.270	0.016	0.050
θ	0°	8°	0°	8°

DIP8 (Package Outline Dimensions)

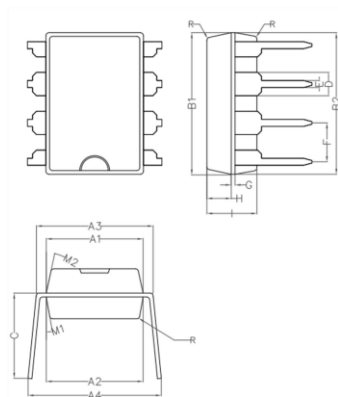

Symbol	Min	Non	Max
A1	6.28	6.33	6.38
A2	6.33	6.38	6.43
A3	7.52	7.62	7.72
A4	7.80	8.40	9.00
B1	9.15	9.20	9.25
B2	9.20	9.25	9.30
C		5.57	
D		1.52	
E	0.43	0.45	0.47
F		2.54	
G		0.25	
H	1.54	1.59	1.64
I	3.22	3.27	3.32
R		0.20	
M1	9°	10°	11°
M2	11°	12°	13°

Disclaimer

All products due to improve reliability, function or design or for other reasons, product specifications and data are subject to change without notice.

Zhuhai Haixin Electronics Co., Ltd., branches, agents, employees, and all persons acting on its or their representatives (collectively, the "zhuhai Haixindianzi"), assumes no responsibility for any errors, inaccuracies or incomplete data contained in the table or any other any disclosure of any information related to the product. (www.haixindianzi.com)

Zhuhai Haixin makes no guarantee, representation or warranty on the product for any particular purpose of any goods or continuous production. To the maximum extent permitted by applicable law on Zhuhai Haixin relinquished: (1) any application and all liability arising out of or use of any products; (2) any and all liability, including but not limited to special, consequential damages or incidental ; (3) any and all implied warranties, including a particular purpose, non-infringement and merchantability guarantee.

Statement on certain types of applications are based on knowledge of the product is often used in a typical application of the general product Haixin Zhuhai demand that the Zhuhai Haixin of. Statement on whether the product is suitable for a particular application is non-binding. It is the customer's responsibility to verify specific product features in the products described in the specification is appropriate for use in a particular application. Parameter data sheets and technical specifications can be provided may vary depending on the application and performance over time. All operating parameters, including typical parameters must be made by customer's technical experts validated for each customer application. Product specifications do not expand or modify Zhuhai Haixin purchasing terms and conditions, including but not limited to warranty herein.

Unless expressly stated in writing, Zhuhai Haixin products are not intended for use in medical, life saving, or life sustaining applications or any other application. Wherein Haixin product failure could lead to personal injury or death, use or sale of products used in Zhuhai Haixin such applications using client did not express their own risk. Contact your authorized Zhuhai Haixin people who are related to product design applications and other terms and conditions in writing.

The information provided in this document and the company's products without a license, express or implied, by estoppel or otherwise, to any intellectual property rights granted to the Haixin act or document. Product names and trademarks referred to herein are trademarks of their respective representatives will be all.

X-ON Electronics

Largest Supplier of Electrical and Electronic Components

Click to view similar products for [Gate Drivers](#) category:

Click to view products by [ZHHXDZ](#) manufacturer:

Other Similar products are found below :

[56956](#) [57.404.7355.5](#) [LT4936](#) [57.904.0755.0](#) [5811-0902](#) [0131700000](#) [LTP70N06](#) [LVP640](#) [5J0-1000LG-SIL](#) [LY2-US-AC240](#) [LY3-UA-DC24](#) [LZNQ2-US-DC12](#) [LZP40N10](#) [60100564](#) [60249-1-CUT-TAPE](#) [0134220000](#) [60713816](#) [61161-90](#) [6131-204-23149P](#) [6131-205-17149P](#) [6131-209-15149P](#) [6131-218-17149P](#) [6131-220-21149P](#) [6131-260-2358P](#) [6131-265-11149P](#) [CS1HCPU63](#) [6150-5001](#) [CSB4](#) [CSK-38-60006](#) [CSK-38-60008](#) [621A](#) [622-4053LF](#) [6273](#) [M40N08MA-H](#) [M55155/29XH06](#) [64-807](#) [65-1930-6](#) [CV500ISB02](#) [M83723/88Y1407N](#) [CWD012-2](#) [CWD03-3](#) [CX3225SB16934D0PPSC2](#) [CX5032GB10000D0PPS02](#) [687-772NF1](#) [70.140.1653](#) [70.200.0653.0](#) [703001B01F060](#) [70-3601](#) [706006D02F0601](#) [706210](#)