

表面安装普通整流二极管

反向电压 50 ~ 1000 V

正向电流 1.5 A

Surface Mount General-purpose Rectifiers

Reverse Voltage 50 ~ 1000 V

Forward Current 1.5 A

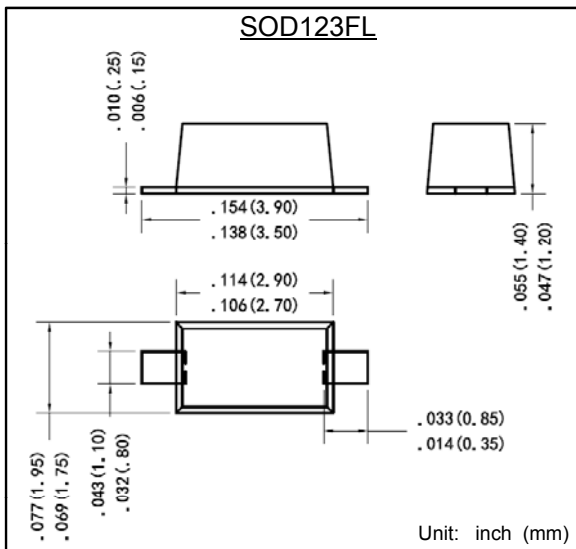

特征 Features

- 反向漏电流低 Low reverse leakage
- 正向浪涌承受能力强 High forward surge capability
- 高信赖性 High reliability
- 高温焊接保证 High temperature soldering guaranteed:
260°C/10 秒
260°C/10seconds
- 引线 and 管体皆符合RoHS标准
Lead and body according with RoHS standard
- 型号后缀“-F”标记无卤素产品
Green compound with suffix "-F" on Marking

机械数据 Mechanical Data

- 封装外形:SOD123FL 塑封 Case:SOD123FL Molded plastic
- 环氧树脂: UL易燃等级: 94V-0
Epoxy: UL 94V-0 rate flame retardant
- 引脚: 镀锡,无铅 Lead: Pure tin plated, lead free

最大值和特性 TA = 25°C 除非另有规定。

Maximum Ratings & Characteristics

Ratings at 25°C ambient temperature unless otherwise specified.

参数 Parameter	符号 Symbols	DS2A	DS2B	DS2D	DS2G	DS2J	DS2K	DS2M	单位 Unit
最大可重复峰值反向电压 Maximum repetitive peak reverse voltage	V_{RRM}	50	100	200	400	600	800	1000	V
最大均方根电压 Maximum RMS voltage	V_{RMS}	35	70	140	280	420	560	700	V
最大直流阻断电压 Maximum DC blocking voltage	V_{DC}	50	100	200	400	600	800	1000	V
最大正向平均整流电流 Maximum average forward rectified current	$I_{F(AV)}$	1.5							A
正向不重复浪涌电流 8.3 ms单一正弦半波 Non-repetitive peak forward surge current 8.3 ms single half sine-wave	I_{FSM}	45							A
最大正向电压 @ $I_F=1.5.0A$ Maximum forward voltage	V_F	1.1							V
最大反向电流 @ V_{DC} Maximum reverse current	I_R	5							μA
		100							
典型热阻 Typical thermal resistance (Note 1)	$R_{\theta JA}$	180							$^{\circ}C/W$
典型结电容 VR=4.0V,f=1MHz Type junction capacitance	C_J	40							pF
工作结温 Operating junction temperature rang	T_J	-55 --- +150							$^{\circ}C$
存储温度 Storage temperature rang	T_{STG}	-55 --- +150							$^{\circ}C$

备注 Note:

1) 安装在PCB板上, 从PN结到周围环境的热阻。

1) Thermal resistance from junction to ambient, PCB mounted.

特性曲线 Characteristic Curves

正向特性曲线 (典型值)

TYPICAL FORWARD CHARACTERISTIC

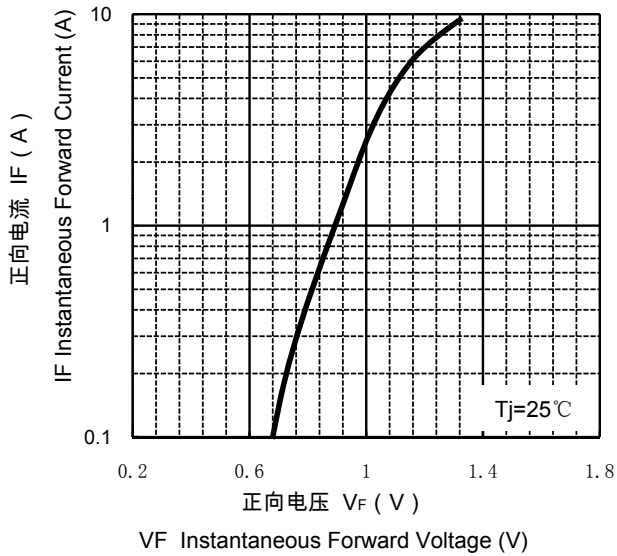

正向电流降额曲线

FORWARD CURRENT DERATING CURVE

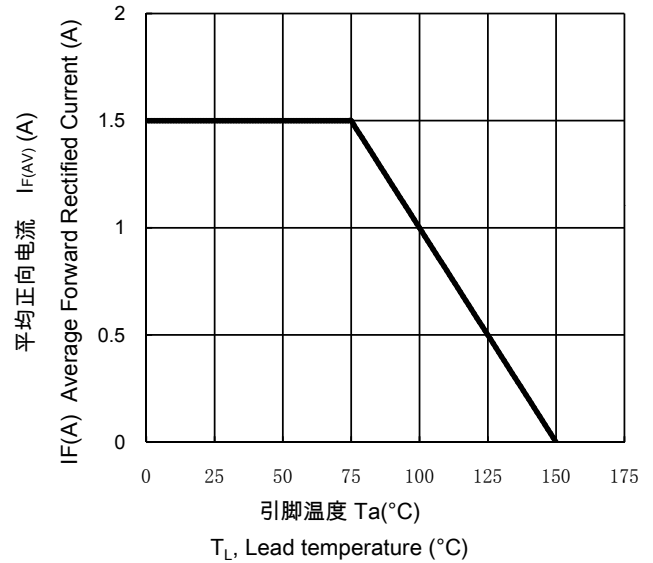

浪涌特性曲线 (最大值)

MAXIMUM NON REPETITIVE
PEAK FORWARD SURGE CURRENT

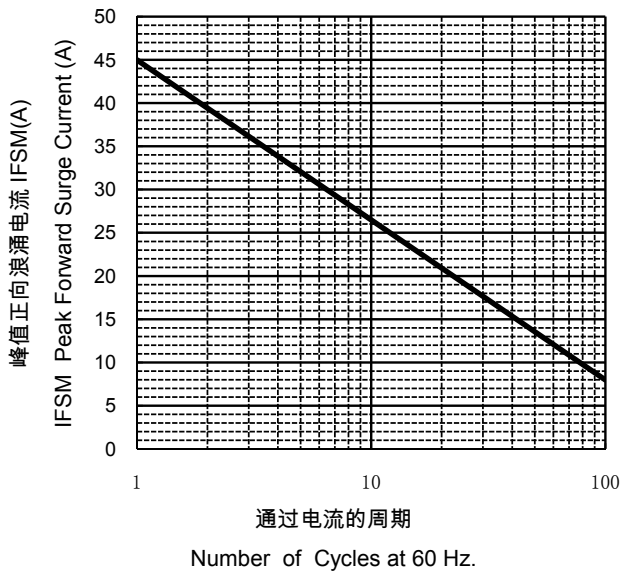

反向特性曲线

Typical Reverse Characteristics

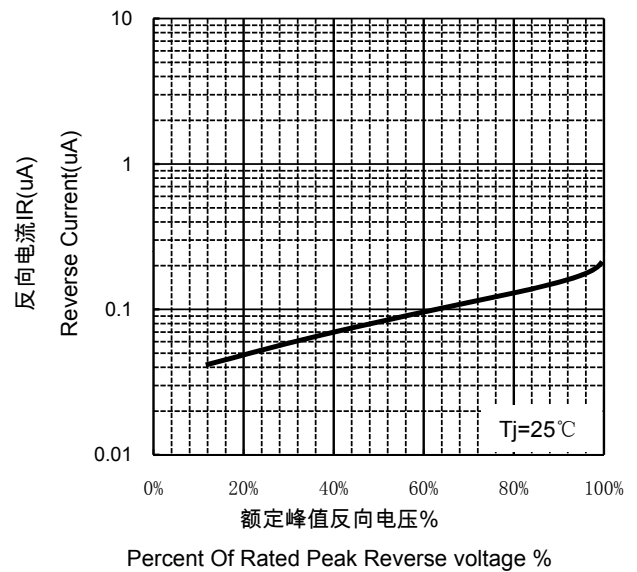

X-ON Electronics

Largest Supplier of Electrical and Electronic Components

Click to view similar products for [Diodes - General Purpose, Power, Switching category](#):

Click to view products by [ZHIDE manufacturer](#):

Other Similar products are found below :

[MCL4151-TR3](#) [MMBD3004S-13-F](#) [RD0306T-H](#) [1N3611](#) [NTE156A](#) [NTE574](#) [NTE6244](#) [1SS193,LF](#) [1SS400CST2RA](#) [SDAA13](#)
[SHN2D02FUTW1T1G](#) [LS4151GS08](#) [1N4449](#) [1N456A](#) [1N4934-E3/73](#) [1N914BTR](#) [D291S45T](#) [BAV300-TR](#) [BAW56DWQ-7-F](#) [BAW75-](#)
[TAP](#) [MM230L-CAA](#) [IDW40E65D1](#) [JAN1N3600](#) [JAN1N4454UR-1](#) [LL4151-GS18](#) [SMMSD4148T3G](#) [BYW95B/A52A](#) [NSVDAN222T1G](#)
[CDSZC01100-HF](#) [LL4150-M-08](#) [1N4454-TR](#) [BAV70HDW-7](#) [BAS28-7](#) [JANTX1N6640](#) [BAW56HDW-13](#) [BAS28 TR](#) [VS-](#)
[HFA04SD60STR-M3](#) [NSVM1MA152WKT1G](#) [1SS388-TP](#) [RGP30D-E3/73](#) [VS-8EWF02S-M3](#) [BAV99TQ-13-F](#) [BAV99HDW-13](#)
[MMDB30-E28X](#) [IDP20C65D2XKSA1](#) [LS4148](#) [IDV15E65D2](#) [NSVM1MA152WAT1G](#) [HN4D02JU\(TE85L,F\)](#) [MMD820-C12](#)