

表面安装肖特基二极管
反向电压 20 ~ 200 V
正向电流 1.0 A

Surface Mounted Schottky Barrier Rectifiers
Reverse Voltage 20 ~ 200 V
Forward Current 1.0 A

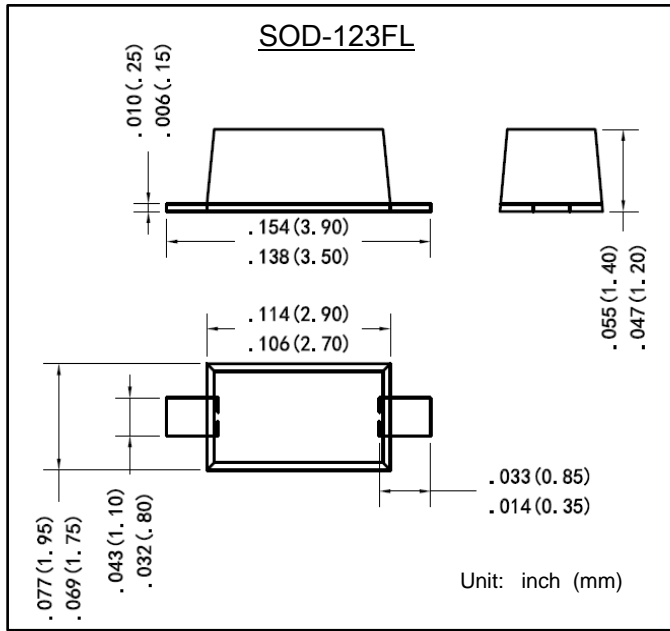

特征 Features

- 反向漏电流低 Low reverse leakage
- 正向浪涌承受能力强 High forward surge capability
- 高信赖性 High reliability
- 高温焊接保证 High temperature soldering guaranteed:
260°C/10 秒
260°C/10seconds
- 引线 and 管体皆符合RoHS标准
Lead and body according with RoHS standard
- 型号后缀“-F”标记无卤素产品
Green compound with suffix "-F" on Marking

机械数据 Mechanical Data

- 封装外形:SOD-123FL塑封 Case:SOD-123FL Molded plastic
- 环氧树脂 : UL易燃等级 : 94V-0
Epoxy: UL 94V-0 rate flame retardant
- 引脚 : 镀锡,无铅 Lead: Pure tin plated, lead free

最大值和特性 TA = 25°C 除非另有规定。

Maximum Ratings & Characteristics Ratings at 25°C ambient temperature unless otherwise specified.

参数 Parameter	符号 Symbols	DSS12	DSS13	DSS14	DSS15	DSS16	DSS18	DSS110	DSS115	DSS120	单位 Unit	
最大可重复峰值反向电压 Maximum repetitive peak reverse voltage	V_{RRM}	20	30	40	50	60	80	100	150	200	V	
最大均方根电压 Maximum RMS voltage	V_{RMS}	14	21	28	35	42	56	70	105	140	V	
最大直流阻断电压 Maximum DC blocking voltage	V_{DC}	20	30	40	50	60	80	100	150	200	V	
最大正向平均整流电流 Maximum average forward rectified current	$I_{F(AV)}$	1.0									A	
正向不重复浪涌电流 8.3 ms单一正弦半波 Non-repetitive peak forward surge current 8.3 ms singlehalf sine-wave	I_{FSM}	30									A	
最大正向电压 @IF=1.0A Maximum forward voltage	V_F	0.55			0.70		0.85		0.92	0.95	V	
最大反向电流 @V _{DC} TA= 25°C Maximum reverse current TA= 100°C	I_R	0.5					0.1				mA	
		20					10					
典型热阻 Typical thermal resistance (Note 1)	$R_{\theta JA}$ $R_{\theta JL}$	180					55					°C/W
典型结电容 VR=4.0V,f=1MHz Type junction capacitance	C_J	90									pF	
工作结温 Operating junction	T_J	-55 --- +125					-55 --- +150					°C
存储温度 Storage temperature rang	T_{STG}	-55 --- +150									°C	

备注 Note:

1) 安装在PCB板上，从PN结到周围环境的热阻。

1) Thermal resistance from junction to ambient , PCB mounted.

特性曲线 Characteristic Curves

正向特性曲线 (典型值)

TYPICAL FORWARD CHARACTERISTIC

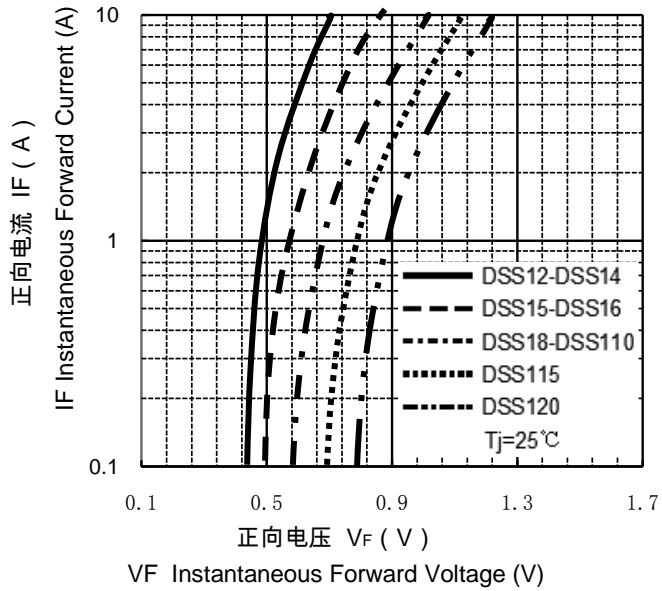

正向电流降额曲线

FORWARD CURRENT DERATING CURVE

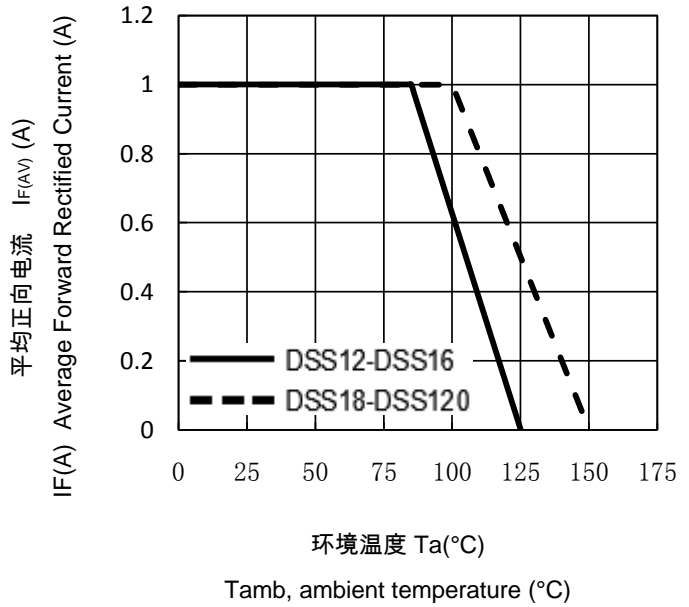

浪涌特性曲线 (最大值)

MAXIMUM NON REPETITIVE
PEAK FORWARD SURGE CURRENT

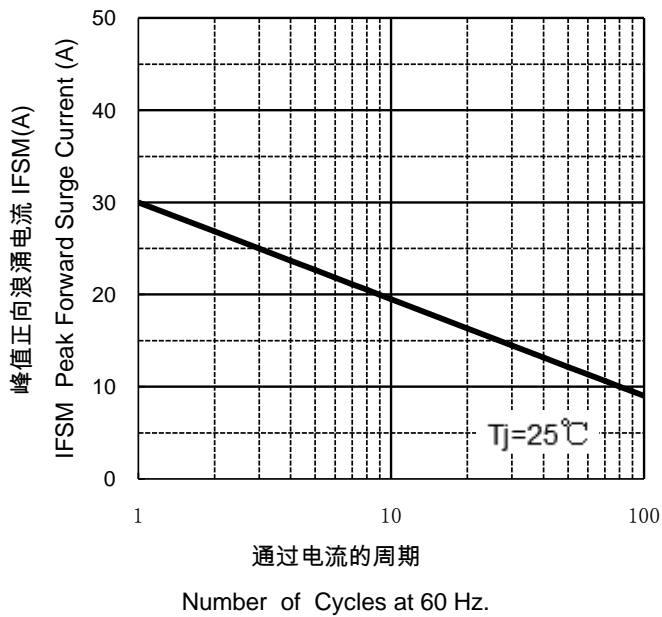

反向特性曲线

Typical Reverse Characteristics

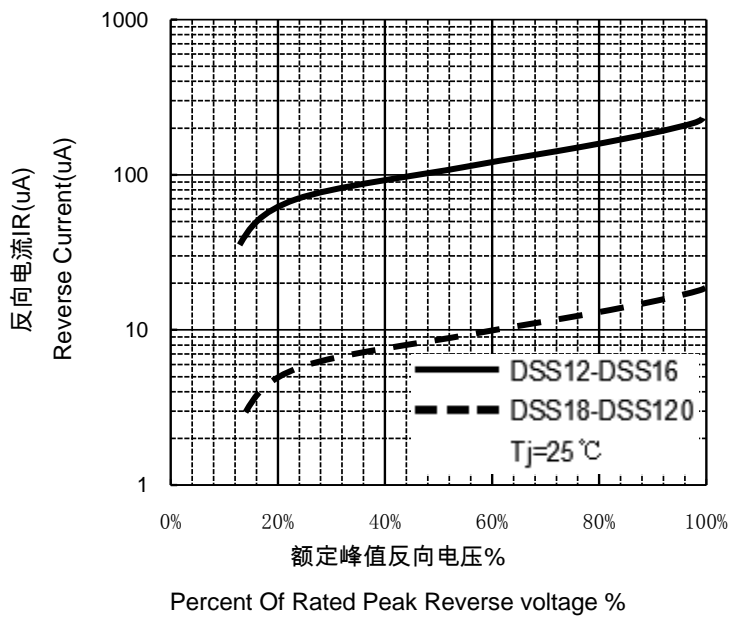

X-ON Electronics

Largest Supplier of Electrical and Electronic Components

Click to view similar products for [Schottky Diodes & Rectifiers](#) category:

Click to view products by [ZHIDE](#) manufacturer:

Other Similar products are found below :

[MA4E2039](#) [MMBD301M3T5G](#) [RB160M-50TR](#) [D83C](#) [BAS16E6433HTMA1](#) [BAS 3010S-02LRH E6327](#) [BAT 54-02LRH E6327](#)
[NRVBAF360T3G](#) [NSR05F40QNXT5G](#) [NTE555](#) [JANS1N6640](#) [SS3003CH-TL-E](#) [GA01SHT18](#) [CRS10I30A\(TE85L,QM](#) [MBRA140TRPBF](#)
[MBRB30H30CT-1G](#) [BAT 15-04R E6152](#) [JANTX1N5712-1](#) [DMJ3940-000](#) [SB007-03C-TB-E](#) [NRVBB20100CTT4G](#) [NRVBM120LT1G](#)
[NTSB30U100CT-1G](#) [CRG04\(T5L,TEMQ\)](#) [ACDBA1100LR-HF](#) [ACDBA1200-HF](#) [ACDBA240-HF](#) [ACDBA3100-HF](#) [CDBQC0530L-HF](#)
[ACDBA260LR-HF](#) [ACDBA1100-HF](#) [10BQ015-M3/5BT](#) [NRVBM120ET1G](#) [VSSB410S-M3/5BT](#) [1N5819T-G](#) [PDS1040Q-13](#) [B160BQ-13-F](#)
[SDM05U20CSP-7](#) [BAS 70-07 E6433](#) [B140S1F-7](#) [HSM560Je3/TR13](#) [DDB2265-000](#) [ZHCS506QTA](#) [HSM190Je3/TR13](#) [B330AF-13](#)
[ACDBUC0230-HF](#) [SDM1U100S1F-7](#) [MBR10200CTF-G1](#) [CDLL5712](#) [DMF2822-000](#)