

Dual Mode Microphone with High SNR Digital Output (Bottom Port)

DESCRIPTION

The ZTS6577 is a high quality, low cost, low power digital output bottom-ported omni-directional MEMS microphone. ZTS6577 consists of a MEMS microphone element and a preamplifier. ZTS6577 has a high SNR and flat wideband frequency response, resulting in natural sound with high intelligibility. Due to built-in filter, ZTS6577 shows high immunity to EMI.

The ZTS6577 is available in a thin 2.75mm X 1.85mm X 0.90mm surface-mount package. It is reflow solder compatible with no sensitivity degradation. The ZTS6577 is Halogen and Lead free.

APPLICATIONS

- Mobile telephones
- PDAs
- Digital video cameras
- Portable media devices with audio input

ORDERING INFORMATION

PART	RoHS	Ship, Quantity
ZTS6577	Yes	Tape and Reel, 5.2K

FEATURES

- 2.75mm X 1.85mm X 0.90 mm surface-mount package
- Stable sensitivity over power supply range of 1.60V-3.60V
- SNR of 64 dB(A)
- Sensitivity of -26dB FS
- Multi Chip Module (MCM) Package

Pins Configuration and Description

Bottom View

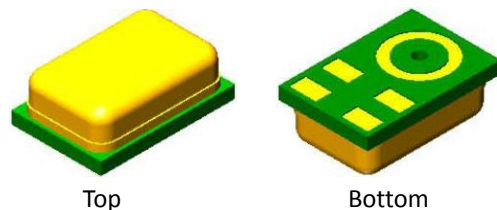
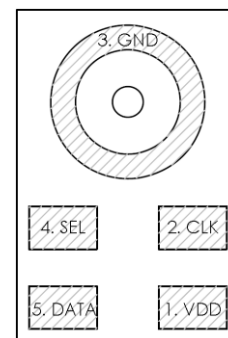

Isometric Views of ZTS6577 Microphone Package

Typical Applications

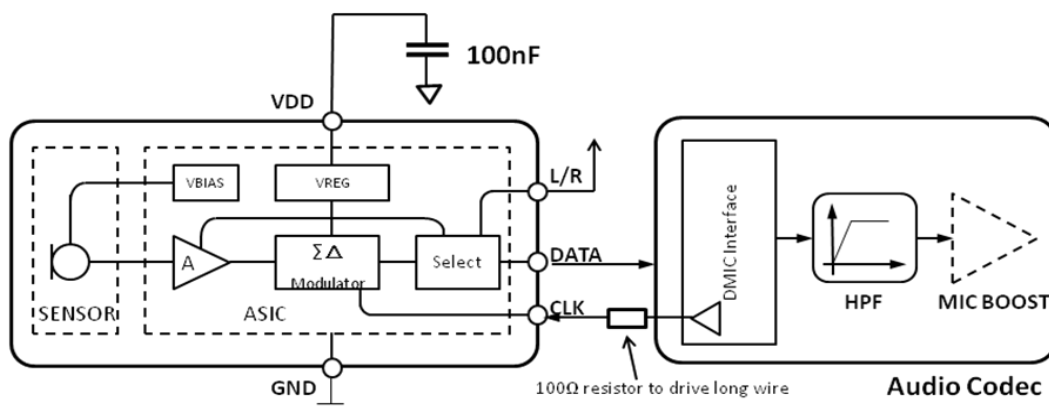

Label	Select	Drives Data After	High-Z After
Data_H	High	Rising Clock Edge	Falling Clock Edge
Data_L	Low (default)	Falling Clock Edge	Rising Clock Edge

Absolute Maximum Ratings

CLOCK to Ground -0.3V to +6.0V
 SELECT, V_{DD}, DATA to Ground -0.3V to +6.0V
 Input Current ±5mA
 Data Output Short Circuit Indefinite to Ground or V_{DD}
 Operating Temperature Range -40°C to +125°C
 Storage Temperature Range -40°C to +125°C

CAUTION: Stresses above those listed in “Absolute Maximum Ratings” may cause permanent damage to the device. This is a stress only rating and operation of the device at these or any other conditions above those indicated in the operational sections of this specification is not implied.

Electro-Static Discharge Sensitivity



This integrated circuit can be damaged by ESD. It is recommended that all integrated circuits be handled with proper precautions. Failure to observe proper handling and installation procedures can cause damage. ESD damage can range from subtle performance degradation to complete device failure.

Pins Description

Pin	Symbol	Description
1	VDD	Power Supply (VDD)
2	CLK	Clock
3	GND	Ground
4	SEL	Select
5	DATA	Data

Microphone Block Diagram

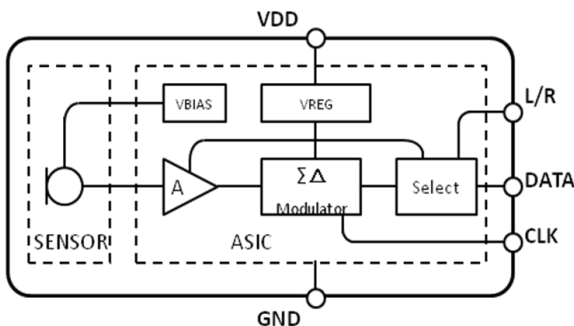

Microphone State Diagram

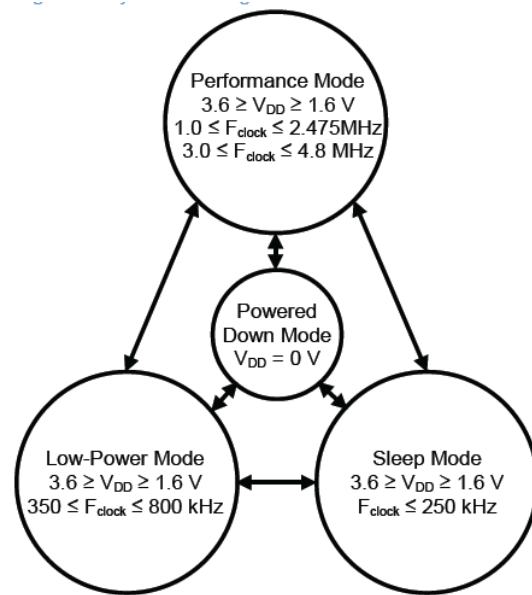

Specifications

(T_A = +15°C ~ +25°C, V_{DD} = +1.8V, f_{clock} = 3.072MHz, R.H. = 60%~70%, no load, unless otherwise noted.)

PARAMETER	Symbol	TEST CONDITIONS		MIN	TYP	MAX	UNIT	
Supply Voltage (Note 1)	V _{DD}			1.60		3.60	V	
Clock Frequency	F _{clock}			1		4.8	MHz	
Current Consumption (Note 1,6)	I _{DD}				600	700	μA	
Standby Current (Sleep Mode) (Note 5,6)	I _{STANDBY}	f _{clock} < 250KHz			50		μA	
Directivity				Omni-directional				
Sensitivity (Note 1)	S	94dB SPL @ 1KHz		-27	-26	-25	dB FS	
Signal to Noise Ratio	SNR	94dB SPL @ 1KHz, A-weighted			64		dB(A)	
Total Harmonic Distortion	THD	114dB SPL @ 1KHz				1	%	
		120dB SPL @ 1KHz				10	%	
Acoustic Overload Point	AOP	10% THD @ 1KHz			120		dB SPL	
Power Supply Rejection Ratio	PSRR	1KHz, 200mV Vp-p, square wave on V _{DD}	V _{DD} = 1.8V		60		dB	
			V _{DD} = 3.3V		60		dB	
Power Supply Rejection	PSR	217Hz, 100mV Vp-p, square wave on V _{DD}	V _{DD} = 1.8V		-90		dB FS	
			V _{DD} = 3.3V		-90			
Polarity		Increasing sound pressure		Increasing density of 1's				
Fall-Asleep Time (Note 2,3)		V _{DD} = On, f _{clock} < 1KHz				10	ms	
Wake-Up Time (Note 2,4)		V _{DD} = On, f _{clock} ≥ 1MHz				10	ms	
Short Circuit Output Current	I _{SC}	Grounded output pin			1	10	mA	
Output Load	C _{LOAD}					100	pF	
Data Format				1/2 cycle PDM				
Clock Duty Cycle				40		60	%	
Clock Rise Time	t _{cr}					10	ns	
Clock Fall Time	t _{ct}					10	ns	
Logic Input/Output Low	V _{IOL}	I _{out} = 1mA		-0.3		0.35×V _{DD}	V	
Logic Input/Output High	V _{IOH}	I _{out} = 1mA		0.65×V _{DD}		V _{DD} +0.3	V	
Delay Time for Valid Data	t _{dv}	CLK = 3.072MHz Oscilloscope: APx525 (probe C _{in} = 24pF)	Data Trans High	1.8	26		82	ns
				3.3	20		80	
			Data Tran Low	1.8	25		80	
				3.3	21		81	
Delay Time for High Z	t _{dz}	CLK = 3.072MHz, Oscilloscope: APx525 (probe C _{in} = 24pF)	Data Trans High	1.8	0		25	ns
				3.3	0		24	
			Data Trans Low	1.8	0		26	
				3.3	0		25	
Settling time	t _s			1.8V		2.65	5.5	ms
				3.3V				
Startup Time		Powered Down →Active Mode	1.8V		2.65	5.5	ms	
			3.3V		2.45	5.3		

($T_A = +15^{\circ}\text{C} \sim +25^{\circ}\text{C}$, $V_{DD} = 3.3\text{V}$, $f_{\text{clock}} = 768\text{KHz}$, R.H. = 60%~70%, no load, unless otherwise noted.)

PARAMETER	Symbol	TEST CONDITIONS	MIN	TYP	MAX	UNIT	
Supply Voltage (Note 1)	V_{DD}		1.60		3.60	V	
Clock Frequency	f_{clock}		350		800	KHz	
Current Consumption (Note 1,6)	I_{DD}			260	300	μA	
Standby Current (Sleep Mode) (Note 5,6)	I_{STANDBY}	$f_{\text{clock}} < 250\text{KHz}$		50		μA	
Directivity			Omni-directional				
Sensitivity (Note 1)	S	94dB SPL @ 1KHz	-27	-26	-25	dB FS	
Signal to Noise Ratio	SNR	94dB SPL @ 1KHz, A-weighted		64		dB(A)	
Total Harmonic Distortion	THD	114dB SPL @ 1KHz			1	%	
		120dB SPL @ 1KHz			10	%	
Acoustic Overload Point	AOP	10% THD @ 1KHz		120		dB SPL	
Power Supply Rejection Ratio	PSRR	1KHz, 200mV Vp-p, square wave on V_{DD}	$V_{DD} = 1.8\text{V}$		60	dB	
			$V_{DD} = 3.3\text{V}$		60	dB	
Power Supply Rejection	PSR	217Hz, 100mV Vp-p, square wave on V_{DD}	$V_{DD} = 1.8\text{V}$		-90	dB FS	
			$V_{DD} = 3.3\text{V}$		-90		
Polarity		Increasing sound pressure	Increasing density of 1's				
Fall-Asleep Time (Note 2,3)		$V_{DD} = \text{On}$, $f_{\text{clock}} < 1\text{KHz}$			10	ms	
Wake-Up Time (Note 2,4)		$V_{DD} = \text{On}$, $f_{\text{clock}} \geq 1\text{MHz}$			10	ms	
Short Circuit Output Current	I_{SC}	Grounded output pin		1	10	mA	
Output Load	C_{LOAD}				100	pF	
Data Format			1/2 cycle PDM				
Clock Duty Cycle			40		60	%	
Clock Rise Time	t_{cr}				10	ns	
Clock Fall Time	t_{ct}				10	ns	
Logic Input/Output Low	V_{IOL}	$I_{\text{out}} = 1\text{mA}$	-0.3		$0.35 \times V_{DD}$	V	
Logic Input/Output High	V_{IOH}	$I_{\text{out}} = 1\text{mA}$	$0.65 \times V_{DD}$		$V_{DD} + 0.3$	V	
Delay Time for Valid Data	t_{dv}	CLK = 3.072MHz Oscilloscope: APx525 (probe Cin = 24pF)	Data Trans High	1.8	26	82	ns
				3.3	20	80	
			Data Trans Low	1.8	25	80	
				3.3	21	81	
Delay Time for High Z	t_{dz}	CLK = 3.072MHz, Oscilloscope: APx525 (probe Cin = 24pF)	Data Trans High	1.8	0	25	ns
				3.3	0	24	
			Data Trans Low	1.8	0	26	
				3.3	0	25	
Settling time	t_{s}		1.8V		2.65	5.5	ms
			3.3V				
Startup Time		Powered Down → Active Mode	1.8V		2.65	5.5	ms
			3.3V		2.45	5.3	

Note 1: 100% tested.

Note 2: Valid microphone states are: Power Down Mode (mic off), Sleep Mode (low current, no output, fast start-up), and Active Mode (normal operation).

Note 3: Time from $f_{\text{clock}} < 1\text{KHz}$ to sleep current specification is met when transitioning from Active to Sleep Mode.

Note 4: Time from $f_{\text{clock}} \geq 1\text{MHz}$ to all applicable specifications when transitioning from Sleep to Active Mode.

Note 5: $\Delta I_{\text{DD}} = 0.5 \times V_{\text{DD}} \times C_{\text{LOAD}} \times f_{\text{clock}}$

Note 6: Specified max values are measured at $V_{\text{DD}} = +3.6\text{V}$.

Timing Diagram

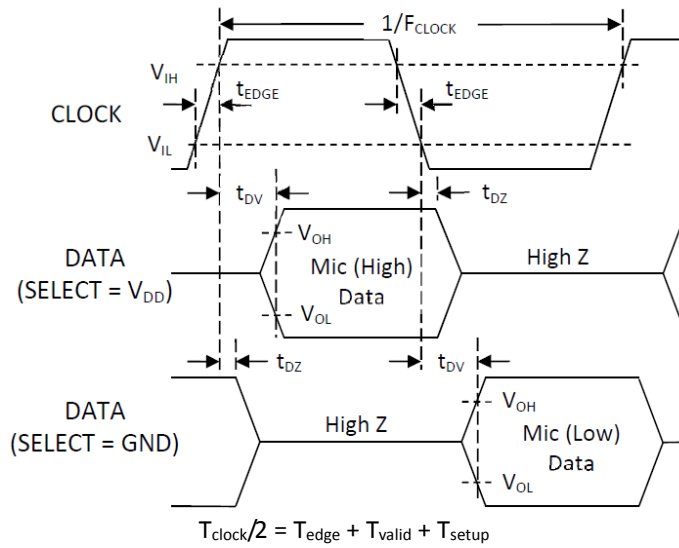

Typical Performance Characteristics

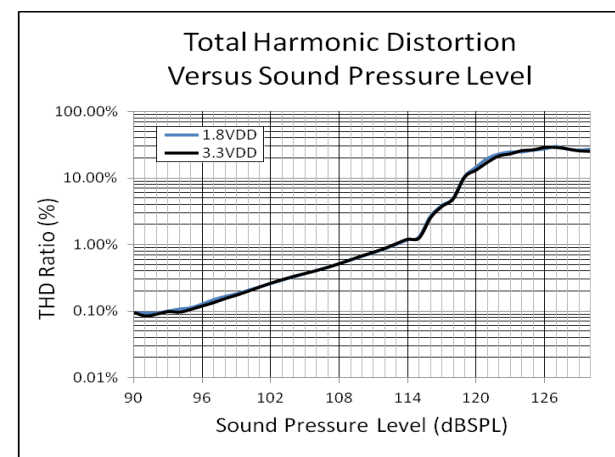
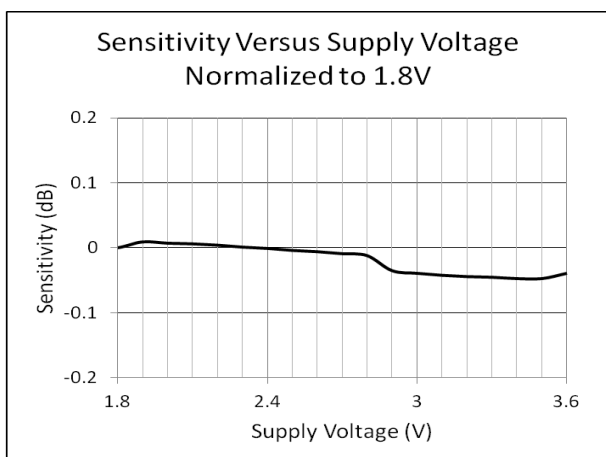
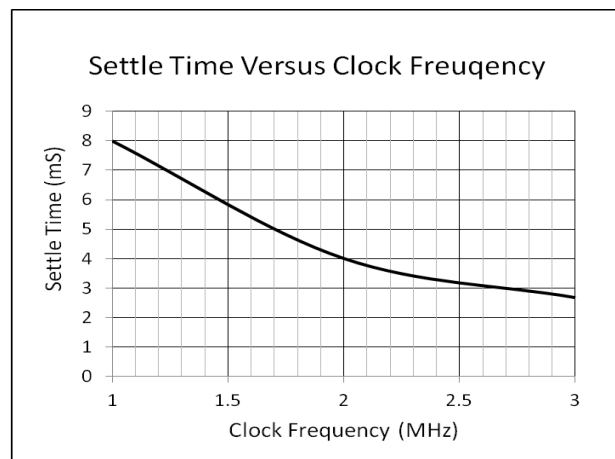
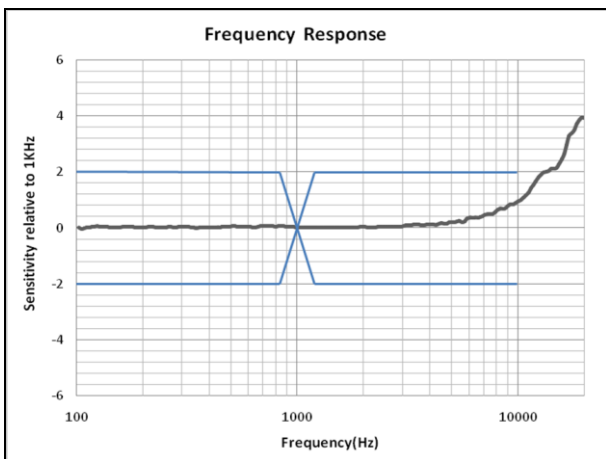

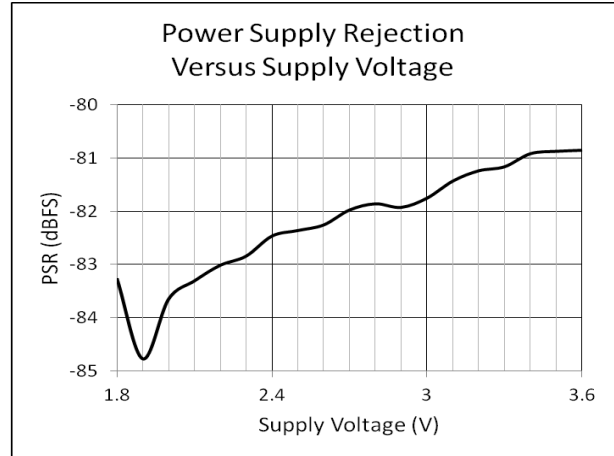
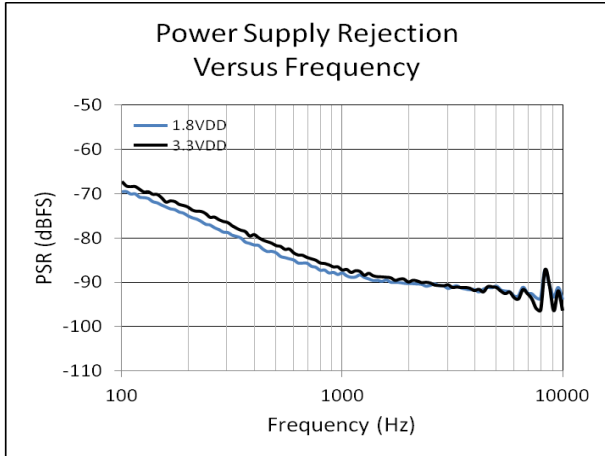

Reliability Specifications

The microphone sensitivity after stress must deviate by no more than $\pm 3\text{dB}$ from the initial value.

1. Heat Test, Operational	Temperature: $125\pm 3^\circ\text{C}$ Duration: 1000 hours Voltage: Applied
2. Cold Test, Operational	Temperature: $-40\pm 3^\circ\text{C}$ Duration: 1000 hours Voltage: Applied
3. Heat Test, Non-Operational	Temperature: $125\pm 3^\circ\text{C}$ Duration: 1000 hours Voltage: Not Applied
4. Cold Test, Non-Operational	Temperature: $-40\pm 3^\circ\text{C}$ Duration: 1000 hours Voltage: Not Applied
5. Thermal Shock Test, Non-Operational	Temperature: $-40\pm 3^\circ\text{C}$ and $125\pm 3^\circ\text{C}$ Duration: 30 minutes each, during 5 minutes ramp, 256 cycles Voltage: Not applied
6. Temperature humidity storage	Temperature: $85\pm 3^\circ\text{C}$ Humidity: $85\pm 3\%RH$ Duration: 1000 hours
	Temperature: $65\pm 3^\circ\text{C}$ Humidity: $95\pm 3\%RH$ Duration: 168 hours
7. Free Fall Test 1.5m	Placed inside test fixture and dropped on concrete from height 1.5m. 4 times by each surface and corner
8. Vibration	4 cycles of 20 to 2000 Hz sinusoidal sweep with 20G peak acceleration lasting 12 minutes in X, Y, and Z directions
9. Mechanical Shock	5 pulses of 10000g in each of the $\pm X$, $\pm Y$, and $\pm Z$ directions
10. Electrostatic Discharge Test	Capacitance: 150pF Resistance: 330Ω Duration: 10 times Air Discharge: Level 4($\pm 15\text{kV}$) Direct contact discharge: Level 4 ($\pm 8\text{kV}$)
11. Human Body Mode	± 2000 Volt
12. Charged-Device Model	± 250 Volt
13. Reflow	5 reflow cycles with peak temperature of 260°C
14. Solderability	$245\pm 5^\circ\text{C}$, 5sec, 95% Tin on pad surface
15. Tumble test	300 tumbles from a height of 1m onto a steel base.
16. HAST	Temperature: $130\pm 3^\circ\text{C}$ Humidity: $85\pm 3\%RH$ Duration: 96 hours Voltage: Applied
17. Air Blow	0.45MPa, distance 3cm, time 10s

MECHANICAL SPECIFICATIONS

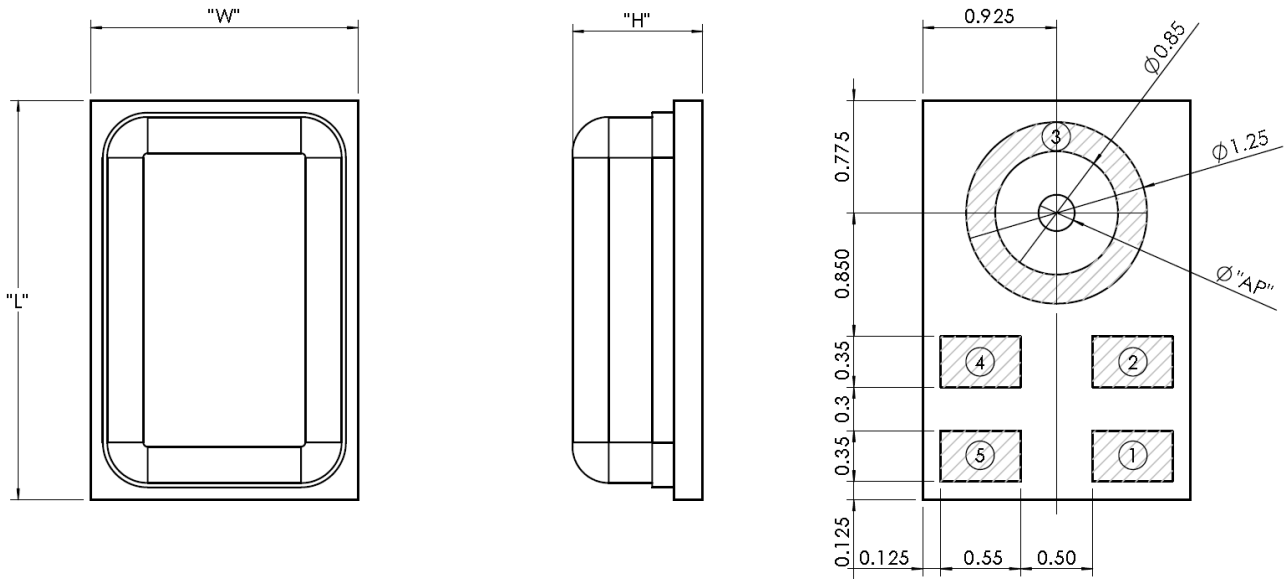

ITEM	DIMENSION	TOLERANCE	UNITS
Length (L)	2.75	± 0.10	mm
Width (W)	1.85	± 0.10	mm
Height (H)	0.90	± 0.10	mm
Acoustic Port (AP)	0.25	± 0.05	mm

RECOMMENDED CUSTOMER LAND PATTERN

The recommended PCB land pattern for the ZTS6577 should have a 1:1 ratio to the solder pads on the microphone package. Care should be taken to avoid applying solder paste to the sound hole in PCB. The dimensions of suggested solder paste pattern refer to the land pattern.

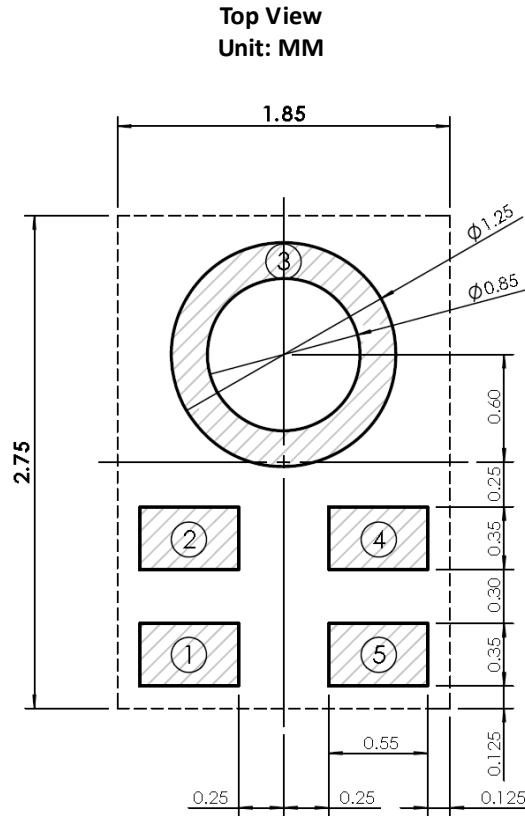

SOLDER FLOW PROFILE

The reflow profile specified in this section describes expected maximum heat exposure of components during the reflow process of NMP product PWBs. Temperature is measured on top of component. All components have to tolerate at least this profile five times (5x) without affecting electrical performance, mechanical performance or reliability.

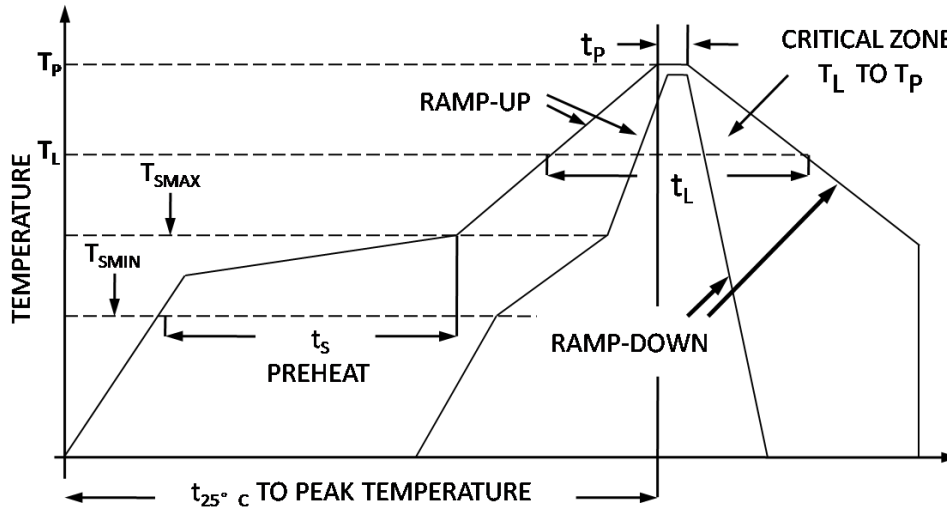

Pb-free and Sn63/Pb37 reflow profile requirements for soldering heat resistance:

Parameter	Reference	Pb-Free	Sn63/Pb37
Average Ramp Rate	T _L to T _P	1.25°C/sec max	1.25 °C /sec max
Preheat	Minimum Temperature	T _{SMIN}	100°C
	Maximum Temperature	T _{SMAX}	200°C
	Time	T _{SMIN} to T _{SMAX}	60sec to 120sec
Ramp-Up Rate	T _{SMAX} to T _L	1.25°C/sec	1.25 °C /sec
Time Maintained Above Liquidous	t _L	60sec to 150sec	60sec to 150sec
Liquidous Temperature	T _L	217°C	183 °C
Peak Temperature	T _P	260°C +0°C/-5°C	215 °C +3 °C /-3 °C
Time Within +5°C of Actual Peak Temperature	t _p	20 sec to 30 sec	20 sec to 30 sec
Ramp-Down Rate	T _{peak}	6°C/sec max	6 °C /sec max
Time +25°C (t _{250C}) to Peak Temperature		8 min max	6 min max

PACKAGING

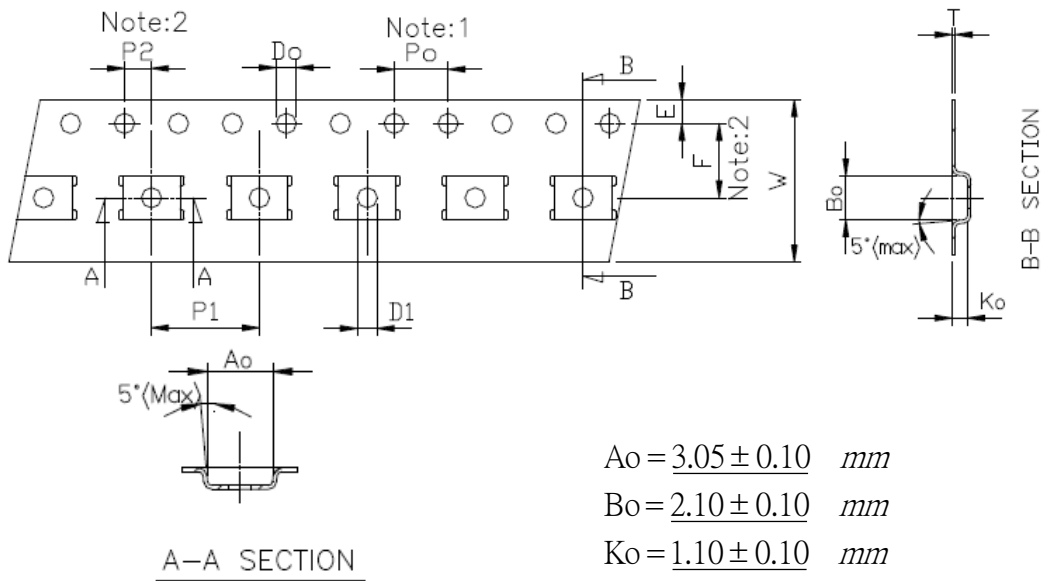

Unit : mm

Symbol	Spec.
K1	-
Po	4.0 ± 0.10
P1	8.0 ± 0.10
P2	2.0 ± 0.05
Do	1.55 ± 0.05
D1	1.50 (MIN)
E	1.75 ± 0.10
F	5.50 ± 0.05
10Po	40.0 ± 0.10
W	12.0 ± 0.20
T	0.30 ± 0.05

Notice :

- 1 · 10 Sprocket hole pitch cumulative tolerance is ± 0.1mm.
- 2 · Pocket position relative to sprocket hole measured as true position of pocket not pocket hole.
- 3 · Ao & Bo measured on a place 0.3mm above the bottom of the pocket to top surface of the carrier.
- 4 · Ko measured from a plane on the inside bottom of the pocket to the top surface of the carrier.
- 5 · Carrier camber shall be not that 1mm per 100mm through a length of 250mm.

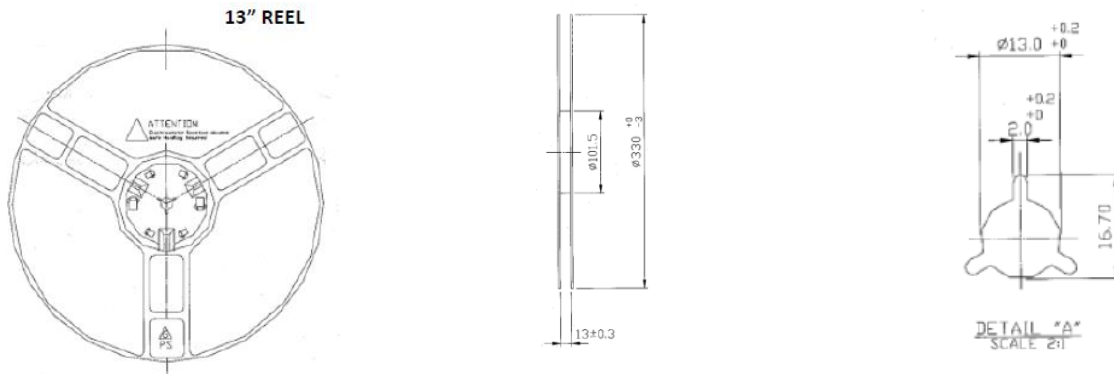

Part NO.	Reel Diameter	Quantity Per Reel	Quantity Per Inner Box	Quantity Per Outer Box
ZTS6577	13"	5200	5200	46800

Dimensions for Inner Box

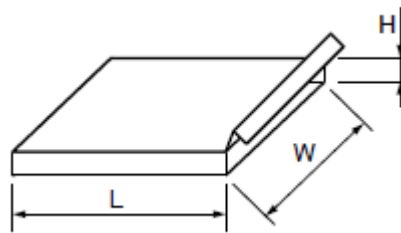

Unit : mm

L	W	H
335	339	45

Dimensions for Outer Box

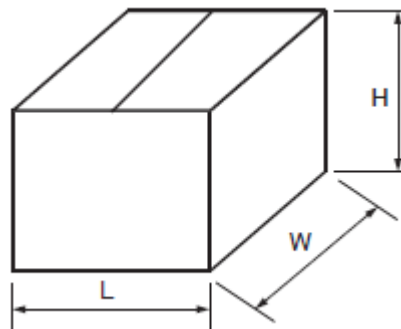

Unit : mm

L	W	H
445	360	372

X-ON Electronics

Largest Supplier of Electrical and Electronic Components

Click to view similar products for [MEMS Microphones](#) category:

Click to view products by [ZILLTEK](#) manufacturer:

Other Similar products are found below :

[8103AC8333S25.00000X](#) [S-VM2020-C](#) [SPK0838HT4H-1](#) [ZTS6577](#) [WMM7018ABHD0-3/TR](#) [ZTS6216](#) [1007079-1](#) [5000AC-8E-25E0-25.000000X](#) [ICS-40180](#) [ICS-40300](#) [ICS-40618](#) [ICS-43432](#) [INMP504ACEZ-R7](#) [INMP510ACEZ-R7](#) [3807ACTC3-33EG-8.19200](#) [501AAA27M0000CAF](#) [SIT9120AC-2C2-25E125.000000](#) [SIT9120AC-2C2-25E200.000000](#) [SIT9121AI-2C3-33E100.000000](#) [SPU0410LR5H-QB](#) [9120AI-2C3-25E100.0000](#) [8002AI-13-33E16.00000](#) [5001AI-2D-18N0-20.000000](#) [UC2000-30GM-IUR2-V15](#) [MP23ABS1TR](#) [MM034202-1](#) [ICS-41350](#) [ICS-40619](#) [MM042602-4](#) [MP34DT06JTR](#) [ICS-52000](#) [SPW0442HR5H-1](#) [MM042602-5](#) [MM033802-1](#) [ICS-43434](#) [ASFLM2-28.224MHZ-LR-T](#) [ICS-40310](#) [ICS-40720](#) [INMP621ACEZ-R7](#) [9003AC-14-33EQ25.00000](#) [SIT9120AC-2C2-33E125.000000](#) [1618AA-13-33S-16.000000G](#) [SPU0414HR5H-SB-7](#) [PMM-3738-VM1000-R](#) [CMM-2718AB-38108-TR](#) [CMM-2718AB-38308-TR](#) [CMM-2718AB-383161-TR](#) [CMM-2718AB-38316-TR](#) [CMM-2718AT-42108-TR](#) [CMM-2718AT-42116-TR](#)