



ZNEO[®] Motor Control Family

Z16FMC[™] Series Motor Control Development Kit

User Manual

UM023402-0811



Warning: DO NOT USE THIS PRODUCT IN LIFE SUPPORT SYSTEMS.

LIFE SUPPORT POLICY

ZILOG'S PRODUCTS ARE NOT AUTHORIZED FOR USE AS CRITICAL COMPONENTS IN LIFE SUPPORT DEVICES OR SYSTEMS WITHOUT THE EXPRESS PRIOR WRITTEN APPROVAL OF THE PRESIDENT AND GENERAL COUNSEL OF ZILOG CORPORATION.

As used herein

Life support devices or systems are devices which (a) are intended for surgical implant into the body, or (b) support or sustain life and whose failure to perform when properly used in accordance with instructions for use provided in the labeling can be reasonably expected to result in a significant injury to the user. A critical component is any component in a life support device or system whose failure to perform can be reasonably expected to cause the failure of the life support device or system or to affect its safety or effectiveness.

Document Disclaimer

©2011 Zilog, Inc. All rights reserved. Information in this publication concerning the devices, applications, or technology described is intended to suggest possible uses and may be superseded. ZILOG, INC. DOES NOT ASSUME LIABILITY FOR OR PROVIDE A REPRESENTATION OF ACCURACY OF THE INFORMATION, DEVICES, OR TECHNOLOGY DESCRIBED IN THIS DOCUMENT. ZILOG ALSO DOES NOT ASSUME LIABILITY FOR INTELLECTUAL PROPERTY INFRINGEMENT RELATED IN ANY MANNER TO USE OF INFORMATION, DEVICES, OR TECHNOLOGY DESCRIBED HEREIN OR OTHERWISE. The information contained within this document has been verified according to the general principles of electrical and mechanical engineering.

Z8, Z8 Encore!, Z8 Encore! XP, Z8 Encore! MC, eZ80, ZNEO and Z16FMC are trademarks or registered trademarks of Zilog, Inc. All other product or service names are the property of their respective owners.

Revision History

Each instance in the Revision History table below reflects a change to this document from its previous version. For more details, click the appropriate links in the table.

Date	Revision Level	Description	Page
Aug 2011	02	Updated schematic diagram in Figure 7 to Rev C per CR#13165.	13
Nov 2010	01	Original issue.	All

**Z16FMC™ Series Motor Control Development Kit
User Manual**



iv

Table of Contents

Revision History	iii
Introduction	1
Kit Features	1
Development Kit Block Diagram	1
MC MDS Module Description	2
Module Features	3
3-Phase Motor Control Application Board	10
Application Board Features	10
ZDSII	11
Troubleshooting and Developer Guidelines	11
Recheck Procedures with the Quick Start Guide	12
Zilog Customer Support Contact	12
Linux Motor Wiring Information	12
Schematic Diagrams	13
Customer Support	19

**Z16FMC™ Series Motor Control Development Kit
User Manual**



vi

Introduction

Zilog's Z16FMC™ Series Motor Control Development Kit aids in the development of motor control applications using Zilog's 64-LQFP Z16FMC Motor Control MCU and provides an application-specific platform for creating a design based on the Z16FMC series microcontroller. The development kit features a Motor Control Modular Development System (MC MDS) module mounted on a 3-Phase Motor Control Application Board. A 24 VDC, 3200RPM 3-phase motor is included with the kit.

Kit Features

The key features of the Z16FMC™ Series Motor Control Development Kit include:

- MC MDS Module
- 3-Phase Motor Control Application Board
- USB Smart Cable with opto-isolator
- 3-phase 24 VDC, 30W, 3200RPM motor with spade connectors and Internal Hall Sensors (powered by external adjustable 24 VDC supply, not included in kit)
- Universal 5 VDC power supply
- Motor Control Software and Documentation CD-ROM

For Z16FMC™ Series Motor Control Development Kit installation and setup instructions, refer to the [Z16FMC™ Series Motor Control Development Kit Quick Start Guide \(QS0079\)](#).

Development Kit Block Diagram

Figure 1 displays a block diagram of the Z16FMC™ Series Motor Control Development Kit.

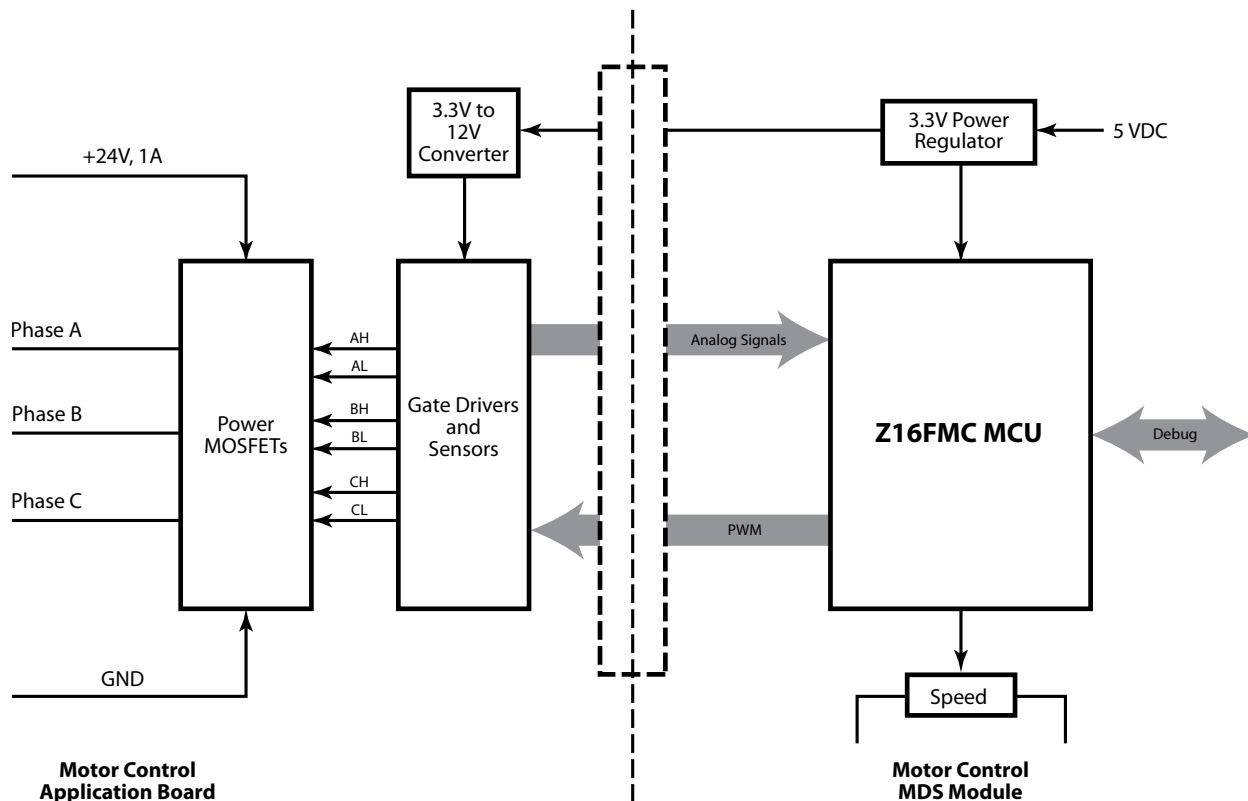

Figure 1. Z16FMC Series Motor Control Development Kit

MC MDS Module Description

The MC MDS Module features the Z16FMC MCU, as shown in Figure 2. It provides circuitry that interfaces the chip to an external development PC running the Zilog Developer Studio II (ZDSII) Integrated Development Environment (IDE), and to the 3-Phase Motor Control Application Board.

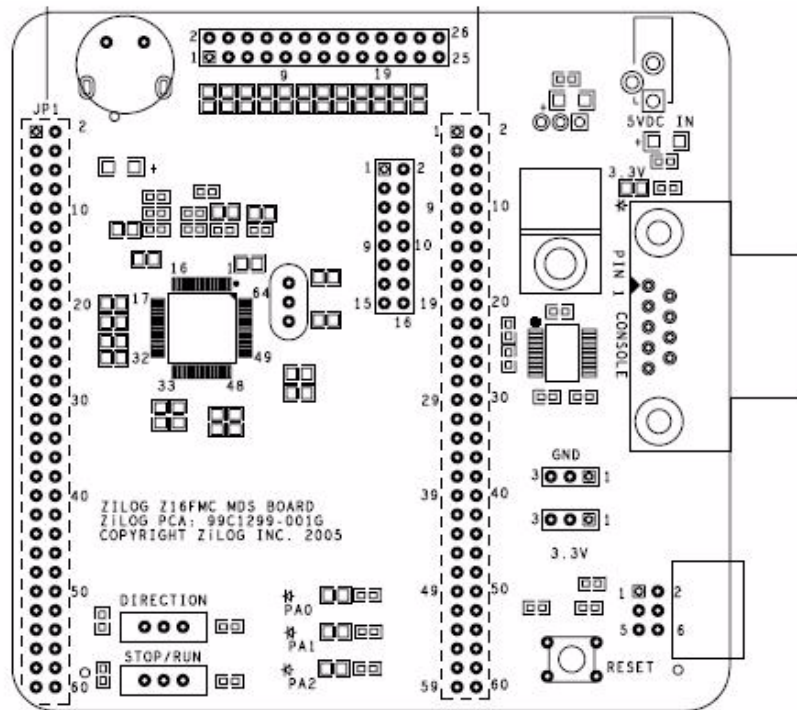

Figure 2. MC MDS Module

Module Features

The features of the MC MDS Module include:

- A Z16FMC device operating at 20MHz with 128KB of internal Flash memory and 4KB of internal register SRAM
- 20MHz ceramic resonator Y1
- Two SPDT switches, S2 and S3(labeled DIRECTION and STOP/RUN, respectively)
- One 5K potentiometer, R7
- Green LED D1 (illuminates when 3.3 VDC is applied to the board)
- Three general-purpose LEDs D2, D3 and D4
- RS-232 port
- 6-pin DBG interface
- Two 60-pin headers for connecting to the 3-Phase Motor Control Application Board (JP1 and JP2; JP1 used for physical mounting only)

Z16FMC MCU

The Z16FMC Series Flash microcontrollers are based on Zilog's advanced ZNEO 16-bit CPU core. Optimized for motor control applications, these devices support the control of single- and multi-phase variable-speed motors. Target applications are large appliances, small appliances and HVAC.

The Z16FMC™ Series Motor Control Development Kit consists of circuitry to support and present all the features of the Z16FMC MCU. The key features of the Z16FMC MCU include:

- 16-bit optimized single-cycle CISC core
- Up to 128KB of in-circuit programmable Flash memory
- Highly integrated digital/analog peripherals
 - Operational Amplifier
 - Analog Comparator
 - Internal Precision Oscillator
 - 4-Channel DMA Controller
 - 12-bit PWM module with three complementary pairs or six independent PWM outputs
- Flexible communication interface including a 9-bit UART with LIN and IrDA, I²C, and ESPI
- 12-Channel, 10-bit ADC with a 2.1µs conversion time

For more information about the Z16FMC MCU, refer to the [Z16FMC Series Motor Control Product Specification \(PS0287\)](#) or the [Z16FMC Series Flash Microcontroller Product Brief \(PB0229\)](#) available from the kit's CD-ROM and also available for download at www.zilog.com.

Connector JP2

Connector JP2 is a 60-pin header that connects I/O from the Z16FMC MCU to the 3-Phase Motor Control Application Board. Figure 3 displays the pin layout. Table 1, which follows, identifies the signals and their functions.

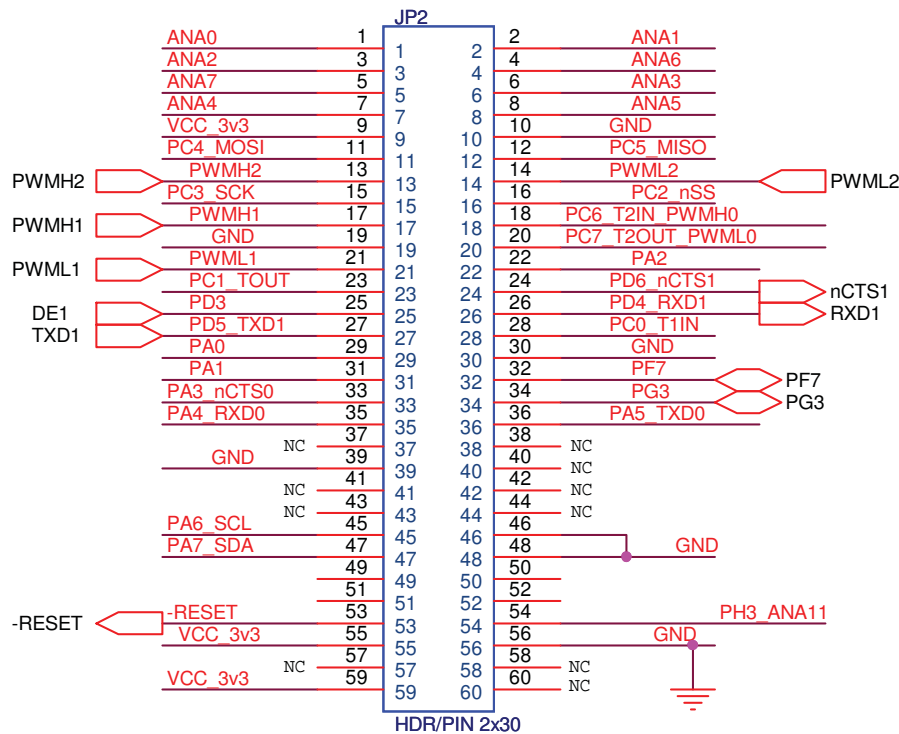

Figure 3. MC MDS Board Connector JP2

Table 1. Connector JP2 Signal Descriptions

Signal	Pins	Direction (with respect to MCU)	Description
ANA0	1	I	Analog input to the ADC.
ANA1	2	I	Analog input to the ADC.
ANA2	3	I	Analog input to the ADC.
ANA6	4	I	Analog input to the ADC.
ANA7	5	I	Analog input to the ADC.
ANA3	6	I	Analog input to the ADC.
ANA4	7	I	Analog input to the ADC.
ANA5	8	I	Analog input to the ADC.
VCC_3v3	9	n/a	3.3 VDC Power.
GND	10	n/a	Ground.

Table 1. Connector JP2 Signal Descriptions (Continued)

Signal	Pins	Direction (with respect to MCU)	Description
PC4_MOSI	11	I/O	Port C[4]; used for general purpose I/O or MOSI.
PC5_MISO	12	I/O	Port C[5]; used for general purpose I/O or MISO.
PWMH2	13	O	PWM High Output.
PWML2	14	O	PWM Low Output.
PC3_SCK	15	I/O	Port C[3]; used for general purpose I/O or SCK.
PC2_nSS	16	I/O	Port C[2]; used for general purpose I/O or nSS.
PWMH1	17	O	PWM High Output.
PC6_T2IN_PWMH0	18	I/O	Port C[6]; used for general purpose I/O or T2IN or PWMH0.
GND	19	n/a	Ground.
PC7_TOUT_PWML0	20	I/O	Port C[7]; used for general purpose I/O or TOUT or PWML0.
PWML1	21	O	PWM Low Output.
PA2	22	I/O	Port A[2]; used for general purpose I/O.
PC1_TOUT	23	I/O	Port C[1]; used for general purpose I/O or T1OUT.
PD6_nCTS1	24	I/O	Port D[6]; used for general purpose I/O or nCTS1.
PD3	25	I/O	Port D[3]; used for general purpose I/O.
PD4_RXD1	26	I/O	Port D[4]; used for general purpose I/O or RXD1.
PD5_TXD1	27	I/O	Port D[5]; used for general purpose I/O or TXD1.
PC0_T1IN	28	I/O	Port C[0]; used for general purpose I/O or T1IN.
PA0	29	I/O	Port A[0]; used for general purpose I/O.
GND	30	n/a	Ground.
PA1	31	I/O	Port A[1]; used for general purpose I/O.
PF7	32	I/O	Port F[7]; used for general purpose I/O.
PA3_nCTS0	33	I/O	Port A[3]; used for general purpose I/O or nCTS0.
PG3	34	I/O	Port G[3]; used for general purpose I/O.
PA4_RXD0	35	I/O	Port A[4]; used for general purpose I/O or RXD0.
PA5_TXD0	36	I/O	Port A[5]; used for general purpose I/O or TXD0.
NC	37	n/a	No Connect.
NC	38	n/a	No Connect.
GND	39	n/a	Ground.
NC	40	n/a	No Connect.

Table 1. Connector JP2 Signal Descriptions (Continued)

Signal	Pins	Direction (with respect to MCU)	Description
NC	41	n/a	No Connect.
NC	42	n/a	No Connect.
NC	43	n/a	No Connect.
NC	44	n/a	No Connect.
PA6_SCL	45	I/O	Port A[6]; used for general purpose I/O or SCL.
GND	46	n/a	Ground.
PA7_SDA	47	I/O	Port A[7]; used for general purpose I/O or SDA.
GND	48	n/a	Ground.
NC	49	n/a	No Connect.
NC	50	n/a	No Connect.
NC	51	n/a	No Connect.
NC	52	n/a	No Connect.
RESET	53	n/a	SET is active Low.
PH3_ANA11	54	I/O	Port H[3]; used for general purpose I/O or ANA11.
VCC_3v3	55	n/a	3.3VDC Power.
GND	56	n/a	Ground.
NC	57	n/a	No Connect.
NC	58	n/a	No Connect.
VCC_3v3	59	n/a	3.3VDC Power.
NC	60	n/a	No Connect.

Connector JP3

Connector JP3 is a 26-pin header that allows access to the analog signals. Figure 4 displays the pin layout. Table 2, which follows, identifies the signals and their functions.

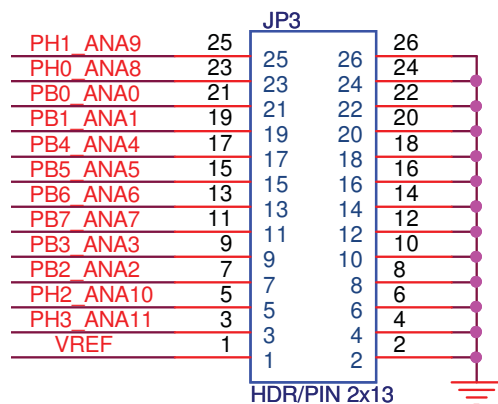

Figure 4. MC MDS Board Connector JP3

Table 2. Connector JP3 Signal Descriptions

Signal	Pins	Direction (with respect to MCU)	Description
V_{REF}	1	Input	ADC Reference Voltage.
ANA11	3	Input	Input to ADC.
ANA10	5	Input	Input to ADC.
ANA2	7	Input	Input to ADC.
ANA3	9	Input	Input to ADC.
ANA7	11	Input	Input to ADC.
ANA6	13	Input	Input to ADC.
ANA5	15	Input	Input to ADC.
ANA4	17	Input	Input to ADC.
ANA1	19	Input	Input to ADC.
ANA0	21	Input	Input to ADC.
ANA8	23	Input	Input to ADC.
ANA9	25	Input	Input to ADC.
GND	2, 4, 6, 8, 10, 12, 14, 16, 18, 20, 22, 24, 26	n/a	Ground.

Connector J1

Connector J1 is a 16-pin header that allows access to all Port E signals. Figure 5 displays the pin layout. Table 3, which follows, identifies the Port E signals and their functions.

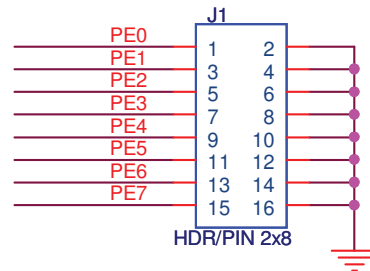

Figure 5. MC MDS Board Connector JP1

Table 3. Connector JP1 Signal Descriptions

Signal	Pins	Direction (with respect to MCU)	Description
PE0	1	I/O	Port E[0].
PE1	3	I/O	Port E[1].
PE2	5	I/O	Port E[2].
PE3	7	I/O	Port E[3].
PE4	9	I/O	Port E[4].
PE5	11	I/O	Port E[5].
PE6	13	I/O	Port E[6].
PE7	15	I/O	Port E[7].
GND	2, 4, 6, 8, 10, 12, 14, 16	n/a	GND.

Jumper and Switch Settings

The MDS module has two SPDT switches (S2 and S3) and a 5K potentiometer (R7) used by the development kit's preloaded demonstration software to perform the following functions:

S2, DIRECTION. Used to change the 3-phase motor spin direction.

S3, STOP/RUN. Used to turn the 3-phase motor ON and OFF.

R7, SPEED. Used to adjust the 3-phase motor RPM.

Physical Dimensions

The footprint of the MC MDS module PCB is 9.5 cm x 9.30 cm. When mounted on the 3-Phase Motor Control Application Board, the overall development kit height is 4.0 cm.

3-Phase Motor Control Application Board

The 3-Phase Motor Control Application Board provides circuitry that drives the 3-phase 24 VDC, 3200 RPM motor included with the development kit (see Figure 6). It provides fused 24 VDC inputs for supplying external adjustable workbench power to run the motor, and interfaces the motor to the Z16FMC MCU mounted on the MC MDS module.

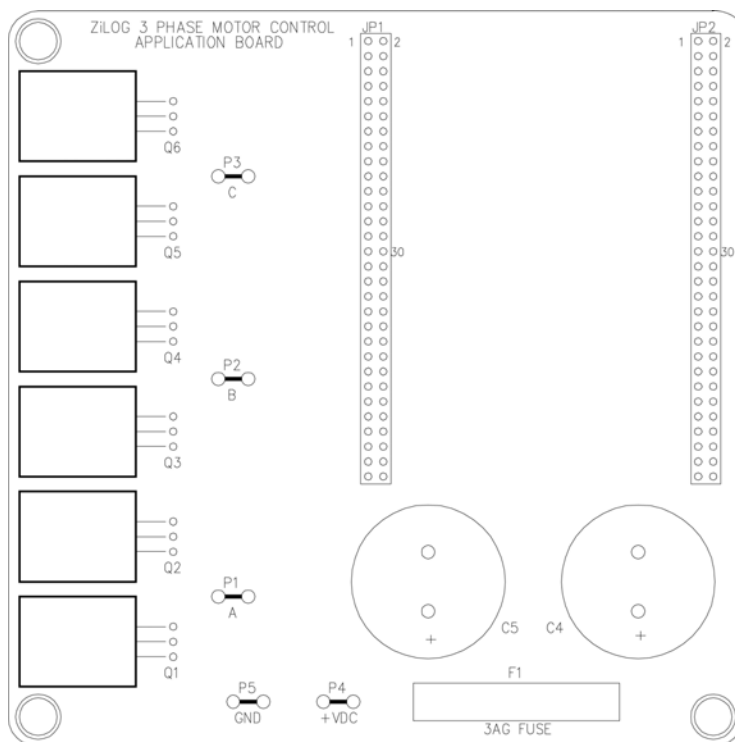

Figure 6. 3-Phase Motor Control Application Board

Application Board Features

The features of 3-Phase Motor Control Application Board include:

- Three spade lug connectors, one for each motor phase
- Dual power MOSFETs for each motor phase

- Heat sink temperature sensor
- Spade lug connectors for power input from adjustable 24 VDC power source (for connection to 3-phase motor)
- 5 A fuse, F1
- Two 60-pin headers for connection to the MC MDS Module (JP1 and JP2; JP1 used for physical mounting only)

Power MOSFETs and Gate Drivers

Each of the phase outputs on spade lugs P1, P2, and P3 are driven by a pair of power MOSFETs, one for the high side and one for the low side. A gate driver circuit is associated with each pair of power MOSFETs.

Fused External Power Interface

An interface to an adjustable 0VDC to 24VDC workbench power supply is provided through spade lug connectors P4 (+) and P5 (-). The input power is fused through 5A 3AG fuse F1.

Physical Dimensions

The footprint of the 3-Phase Motor Control Application Board PCB is 12.44cm x 12.44cm. With the MC MDS module mounted on it, the overall development kit height is 4.31 cm.

ZDSII

The Zilog Developer Studio II (ZDSII) Integrated Development Environment (IDE) is a complete stand-alone system that provides a state-of-the-art development environment. Based on the Windows® XP/Vista-32/Win2000-SP4 user interfaces, ZDSII integrates a language-sensitive editor, project manager, C-Compiler, assembler, linker, librarian, and source-level symbolic debugger that supports the Z16FMC Series of devices.

Troubleshooting and Developer Guidelines

Before contacting Zilog Customer Support to submit a problem report, follow the steps below. If there is a hardware failure, contact a local Zilog representative for assistance.

Recheck Procedures with the Quick Start Guide

Follow the procedures in the [Z16FMC™ Series Motor Control Development Kit Quick Start Guide \(QS0079\)](#) – contained in the kit – and verify that the kit is set up as specified in the document.

Zilog Customer Support Contact

For additional troubleshooting solutions, refer to *ZDSII Online Help*. For valuable information about customer and technical support, as well as hardware and software development tools, visit the Zilog website at www.zilog.com, where you'll also find the latest released versions of ZDSII.

Linux Motor Wiring Information

The Linux 3-phase motor included with the development kit provides three heavy-gauge wires for phase connections and five light-gauge wires used to power and access internal sensors, as indicated in Table 4.

Table 4. 3-Phase Motor Wiring Information

Wire	Description
Heavy-gauge white wire	Motor Phase A connection
Heavy-gauge blue wire	Motor Phase B connection
Heavy-gauge green wire	Motor Phase C connection
Light-gauge red wire	Sensor power V_{CC} (+)
Light-gauge black wire	Sensor power ground (-)
Light-gauge white wire	Sensor signal S_A
Light-gauge blue wire	Sensor signal S_B
Light-gauge green wire	Sensor signal S_C

Schematic Diagrams

Figures 7 through 9 display schematics for the 3-Phase Motor Control Application Board.

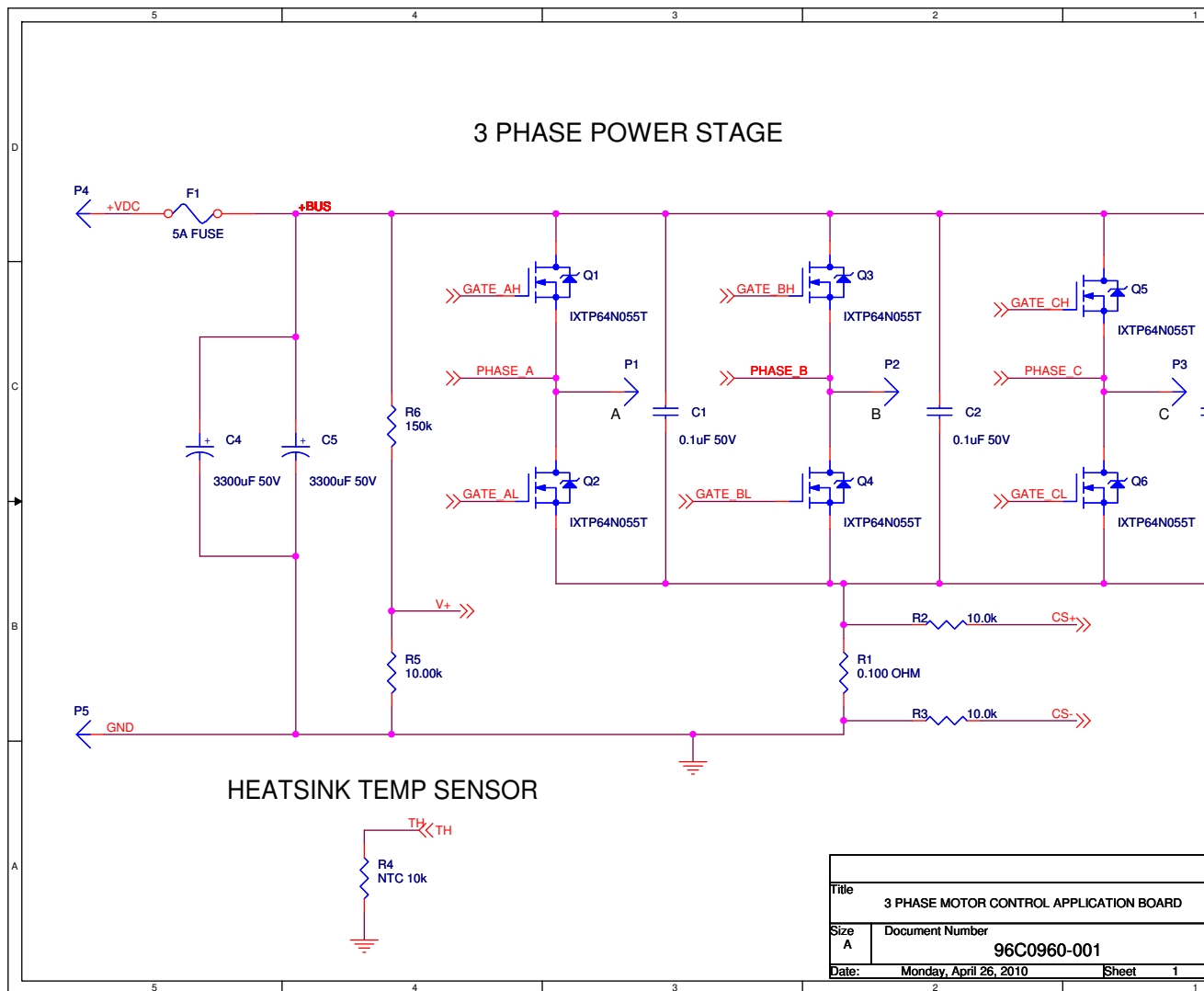

Figure 7. 3-Phase Motor Control Application Board Schematic, #1 of 3

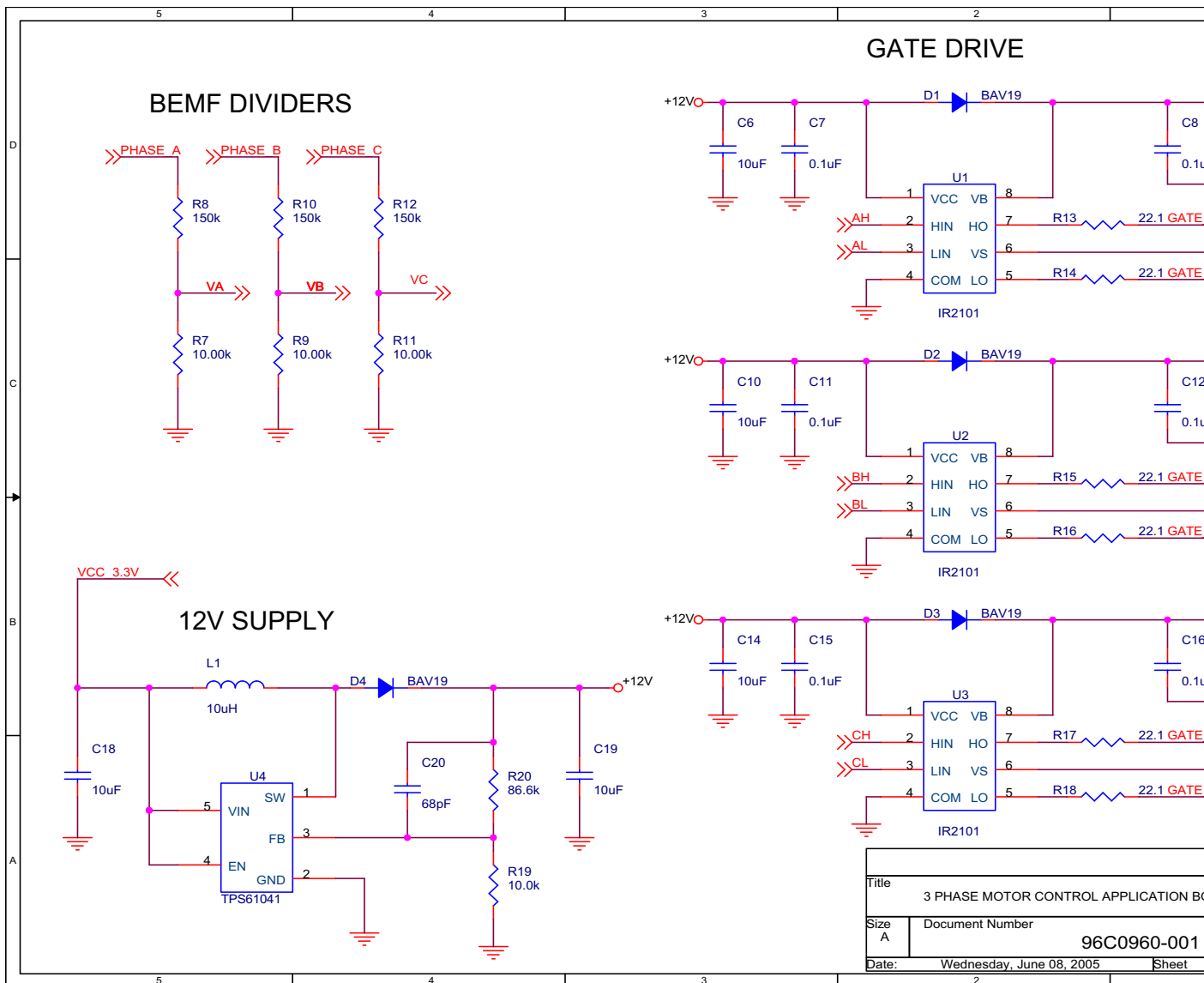

Figure 8. 3-Phase Motor Control Application Board Schematic, #2 of 3

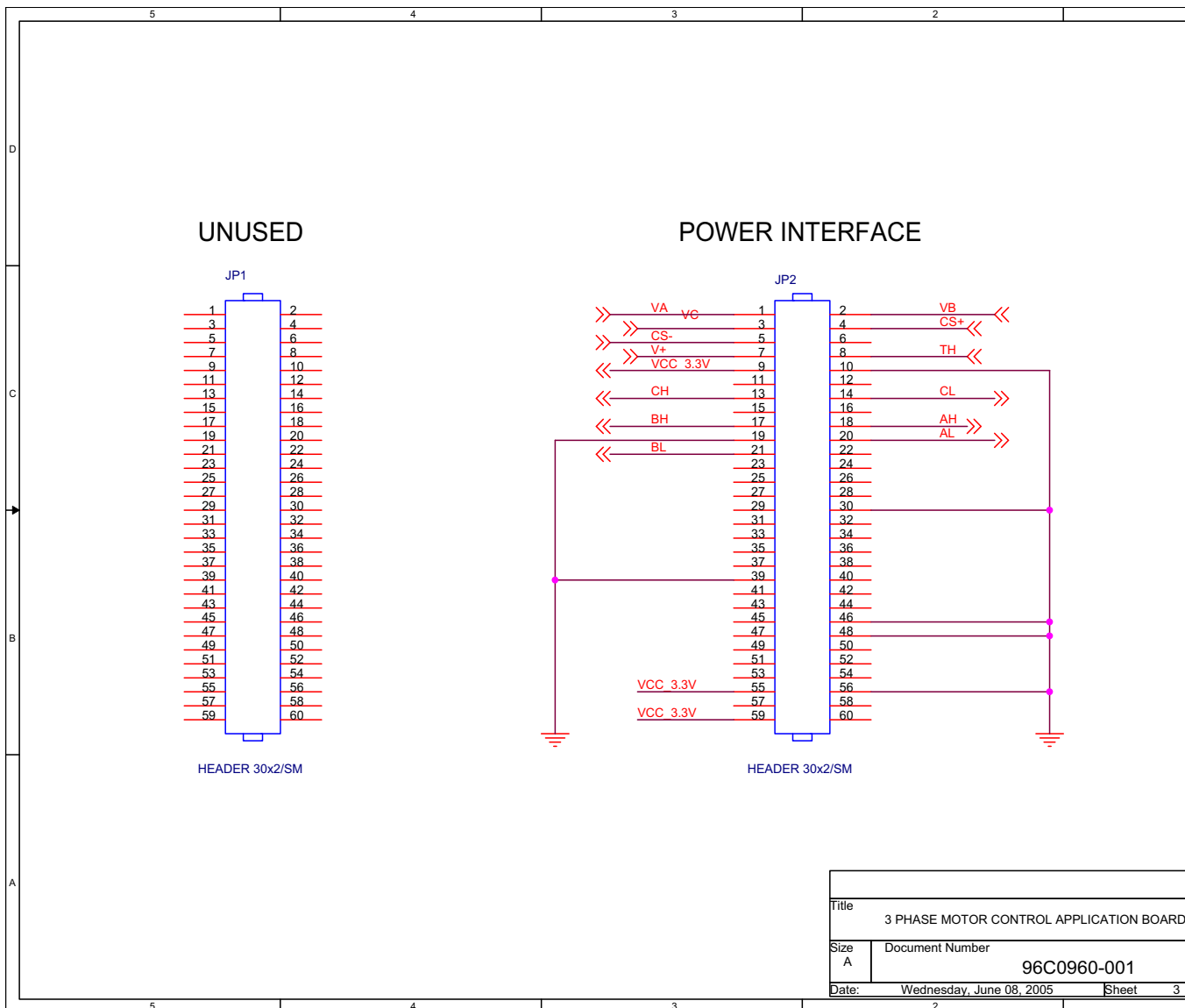

Figure 9. 3-Phase Motor Control Application Board Schematic, #3 of 3

Title		3 PHASE MOTOR CONTROL APPLICATION BOARD	
Size	Document Number	96C0960-001	
A			
Date:	Wednesday, June 08, 2005	Sheet	3

Z16FMC™ Series Motor Control Development Kit

User Manual



Figures 10 through 12 display schematics of the MC MDS Board and Module.

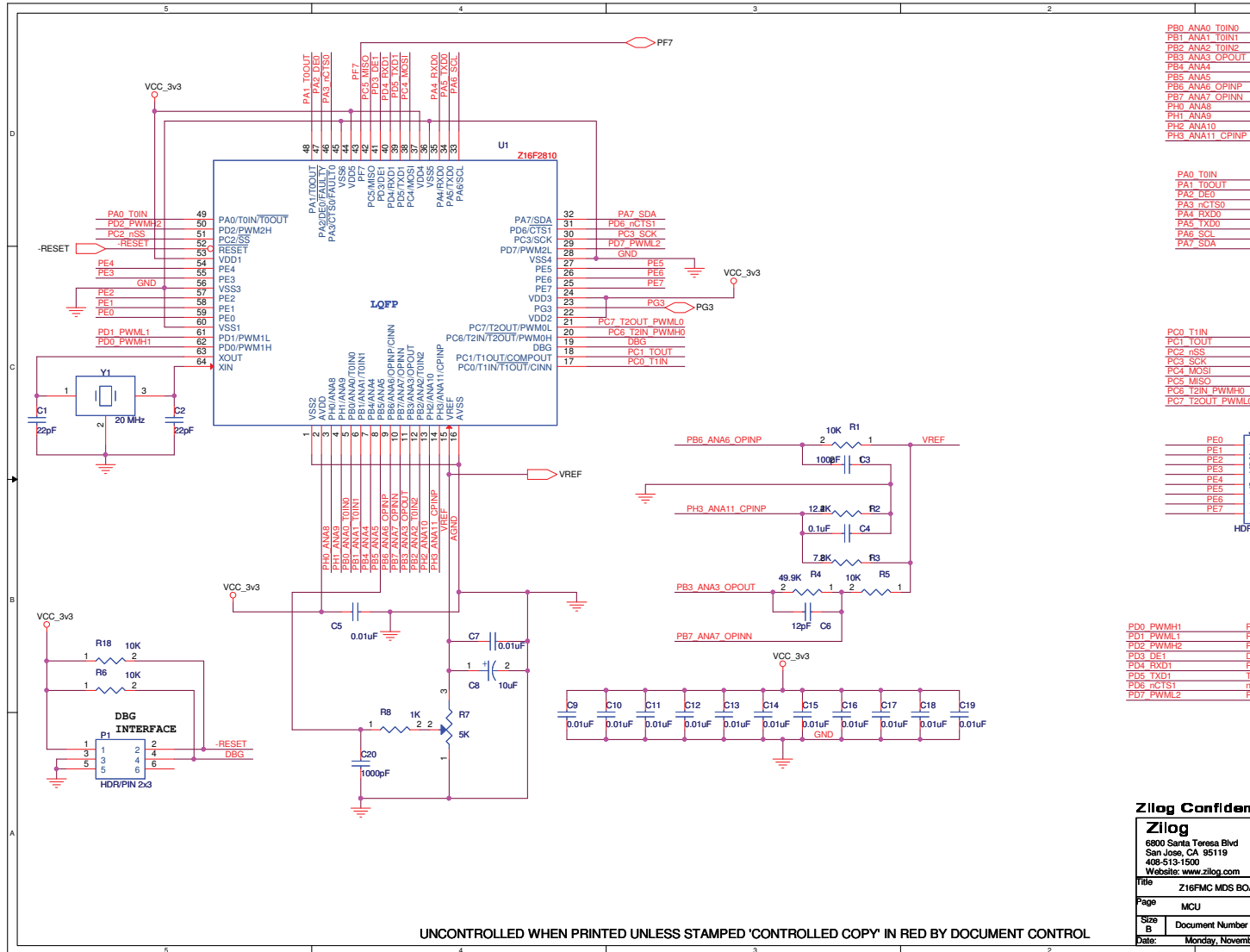

Figure 10. Z16FMC MDS Board Schematic, #1 of 3

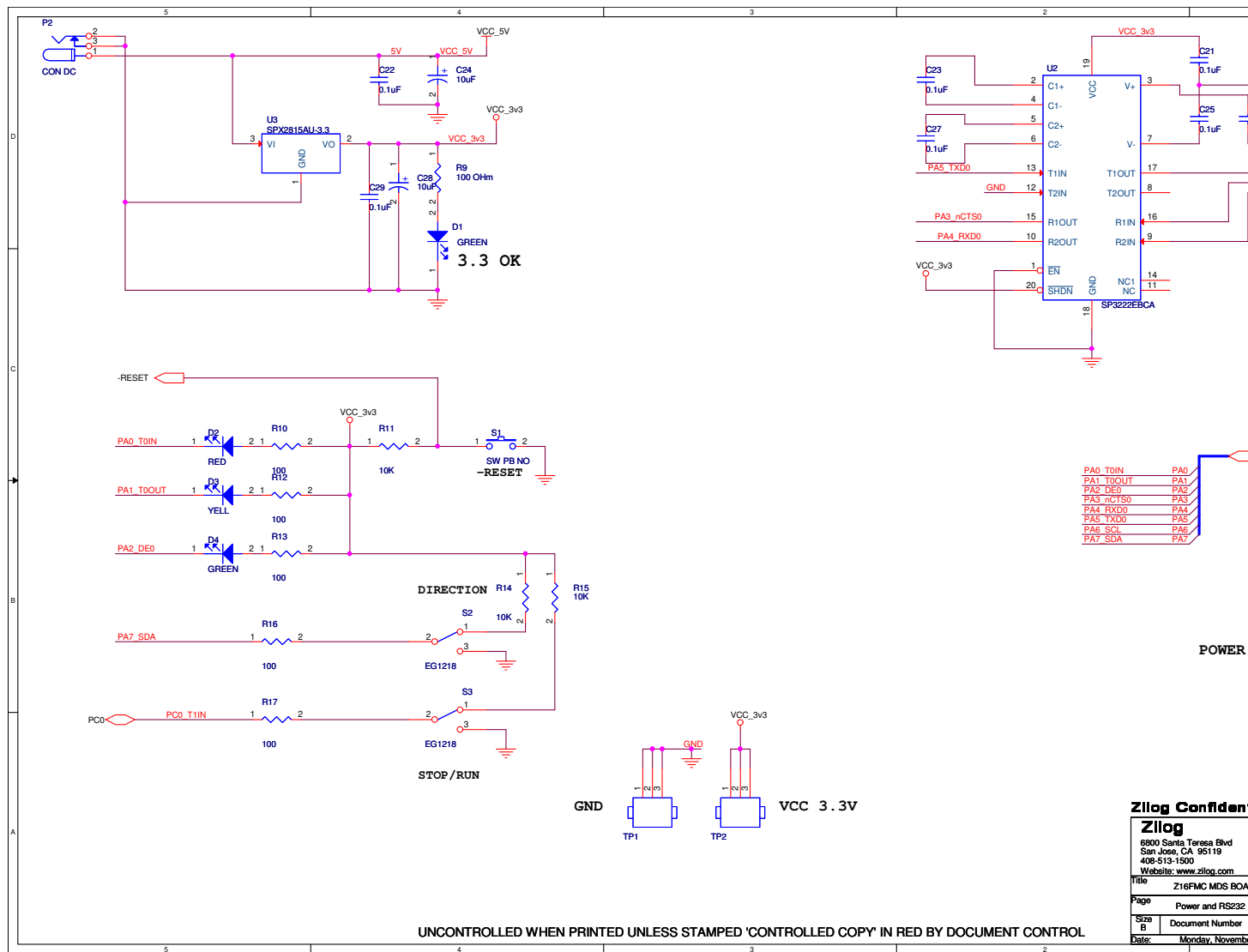

Figure 11. Z16FMC MDS Board Schematic, #2 of 3

Z16FMC™ Series Motor Control Development Kit

User Manual

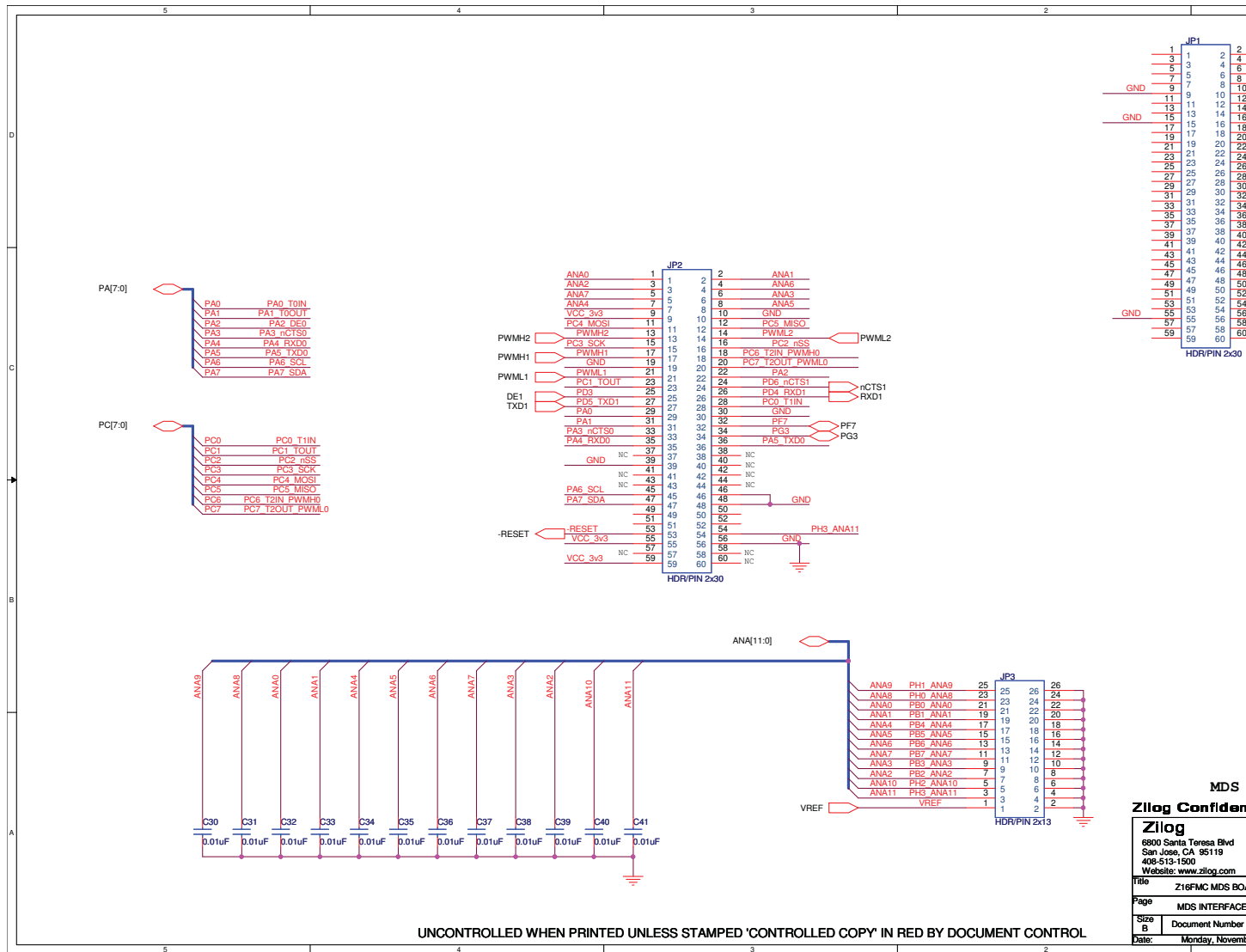

Figure 12. Z16FMC MDS Board Schematic, #3 of 3

Customer Support

To share comments, get your technical questions answered, or report issues you may be experiencing with our products, please visit Zilog's Technical Support page at <http://support.zilog.com>.

To learn more about this product, find additional documentation, or to discover other facets about Zilog product offerings, please visit the [Zilog Knowledge Base](#) or consider participating in the [Zilog Forum](#).

This publication is subject to replacement by a later edition. To determine whether a later edition exists, please visit the Zilog website at <http://www.zilog.com>.

**Z16FMC™ Series Motor Control Development Kit
User Manual**



20

X-ON Electronics

Largest Supplier of Electrical and Electronic Components

Click to view similar products for [Motor/Motion/Ignition Controllers & Drivers](#) category:

Click to view products by [ZiLOG](#) manufacturer:

Other Similar products are found below :

[FSB50550TB2](#) [FSBF15CH60BTH](#) [MSVCPM2-63-12](#) [MSVGW45-14-2](#) [MSVGW54-14-3](#) [MSVGW54-14-5](#) [NTE7043](#) [LA6565VR-TLM-E](#)
[LB11650-E](#) [LB1837M-TLM-E](#) [LB1845DAZ-XE](#) [LC898300XA-MH](#) [SS30-TE-L-E](#) [26700](#) [LV8281VR-TLM-H](#) [BA5839FP-E2](#) [IRAM236-1067A](#) [LA6584JA-AH](#) [LB11847L-E](#) [NCV70501DW002R2G](#) [AH293-PL-B](#) [STK672-630CN-E](#) [TND315S-TL-2H](#) [FNA23060](#) [FSB50250AB](#)
[FNA41060](#) [MSVB54](#) [MSVBTC50E](#) [MSVCPM3-54-12](#) [MSVCPM3-63-12](#) [MSVCPM4-63-12](#) [MSVTA120](#) [FSB50550AB](#)
[NCV70501DW002G](#) [LC898301XA-MH](#) [LV8413GP-TE-L-E](#) [MSVGW45-14-3](#) [MSVGW45-14-4](#) [MSVGW45-14-5](#) [MSVGW54-14-4](#)
[STK984-091A-E](#) [SLA7026M](#) [MP6519GQ-Z](#) [LB11651-E](#) [IRSM515-025DA4](#) [LV8127T-TLM-H](#) [NCP81382MNTXG](#) [TDA21801](#)
[LB11851FA-BH](#) [NCV70627DQ001R2G](#)