



**Z86017/Z86M17**

***PCMCIA Interface***

**Preliminary Customer Procurement Specification**

PS011101-0601



This publication is subject to replacement by a later edition. To determine whether a later edition exists, or to request copies of publications, contact:

**ZiLOG Worldwide Headquarters**

910 E. Hamilton Avenue  
Campbell, CA 95008  
Telephone: 408.558.8500  
Fax: 408.558.8300  
[www.ZiLOG.com](http://www.ZiLOG.com)

Windows is a registered trademark of Microsoft Corporation.

**Document Disclaimer**

©2001 by ZiLOG, Inc. All rights reserved. Information in this publication concerning the devices, applications, or technology described is intended to suggest possible uses and may be superseded. ZiLOG, INC. DOES NOT ASSUME LIABILITY FOR OR PROVIDE A REPRESENTATION OF ACCURACY OF THE INFORMATION, DEVICES, OR TECHNOLOGY DESCRIBED IN THIS DOCUMENT. ZiLOG ALSO DOES NOT ASSUME LIABILITY FOR INTELLECTUAL PROPERTY INFRINGEMENT RELATED IN ANY MANNER TO USE OF INFORMATION, DEVICES, OR TECHNOLOGY DESCRIBED HEREIN OR OTHERWISE. Devices sold by ZiLOG, Inc. are covered by warranty and limitation of liability provisions appearing in the ZiLOG, Inc. Terms and Conditions of Sale. ZiLOG, Inc. makes no warranty of merchantability or fitness for any purpose Except with the express written approval of ZiLOG, use of information, devices, or technology as critical components of life support systems is not authorized. No licenses are conveyed, implicitly or otherwise, by this document under any intellectual property rights.



# Z86017/Z86M17

## PCMCIA INTERFACE

### FEATURES

Part	RAM* (Bytes)	Speed (MHz)
Z86017	256	20
Z86M17	256	20

\*Attribute

### Supports Multiple Applications

- 256 Bytes of Attribute Memory
- Five Configuration Registers
- Three Additional Registers to Support EEPROM Programming
- Three Programmable Memory or I/O Map Ranges
- Conforms to PCMCIA Standards
- EXCA Register Compatible

### Translation Capabilities

- PCMCIA to IDE Translation
- IDE to IDE Mapping, Pass Through Mode
- Direct Memory Access (DMA) Support

### GENERAL DESCRIPTION

The Z86017 is a general-purpose PCMCIA adaptor chip used on the card side of the interface. The Z86017 easily configures to all types of memory and I/O mapped peripheral hardware. Mapping is performed from the I/O and Memory mapped PCMCIA to local peripheral ICs that support Ethernet controllers, UARTs, modems, printer ports, solid state memory, rotating disk memory, and other peripheral devices.

The Z86017 can be used in a stand-alone configuration without the use of a local processor by providing all of the attribute memory, CCRs, range, interrupt types through a serial EEPROM. The serial EEPROM is read automatically using an internal EEPROM sequencer. The Z86017 can also be configured through a local processor for use on intelligent controller systems.

#### Notes:

All Signals with a preceding front slash, "/", are active Low, e.g., B/W (WORD is active Low); /BW (BYTE is active Low, only).

Power connections follow conventional descriptions below:

Connection	Circuit	Device
Power	V <sub>CC</sub>	V <sub>DD</sub>
Ground	GND	V <sub>SS</sub>

**GENERAL DESCRIPTION (Continued)**

The local processor connects to the Z86017 through the serial interface or can be programmed through an external EEPROM. The Z86017 provides for the PCMCIA to ATA/

IDE translation, ATA/IDE to ATA/IDE mapping, or PCMCIA to three general-purpose maps.

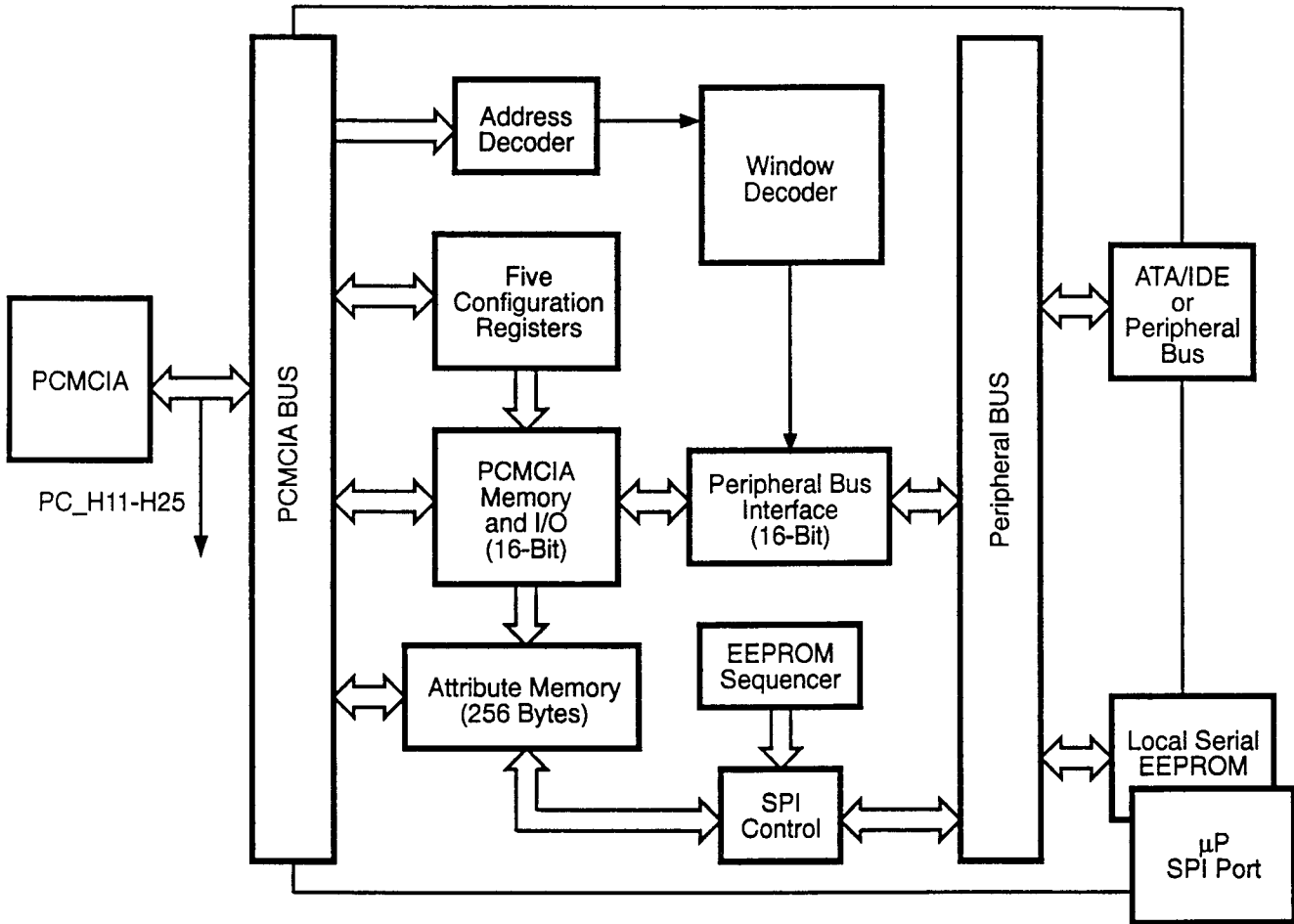

**Z86017 Functional Block Diagram**

The Z86017 supports three general-purpose maps and one special map for PCMCIA to ATA/IDE Transactions .

### Address Mapping Circuit

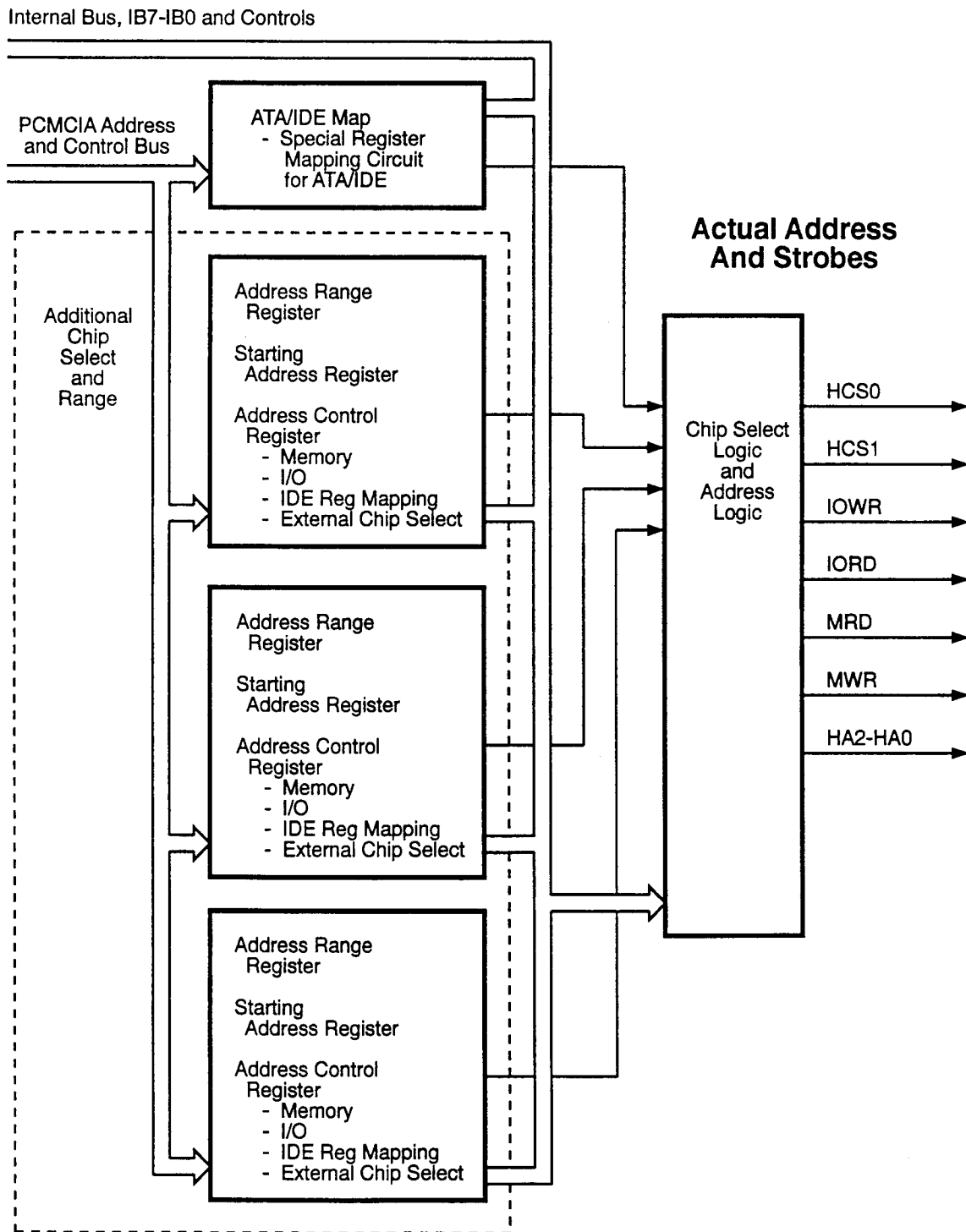

Connection Block Diagram

**GENERAL DESCRIPTION** (Continued)

The Z86017 IC can become an EEPROM interface master or a local processor slave. There are two independent

sequencer circuits in the IC to provide for the master and slave operation.

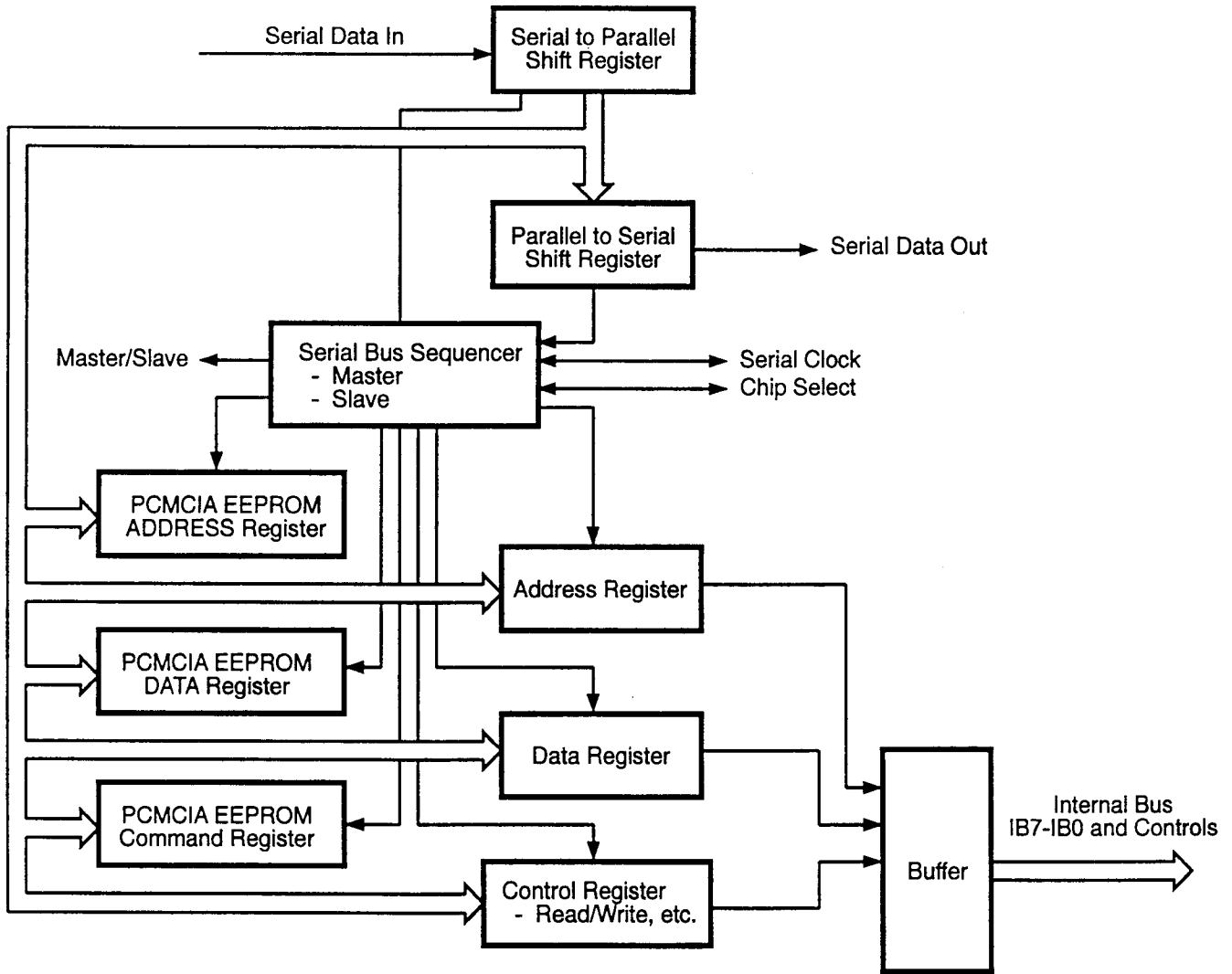

**Serial Interface Diagram**

The Z86017 IC provides the five standard PCMCIA registers. Four additional registers have been added to provide

for remote programming of the EEPROM and Revision Control Status Information.

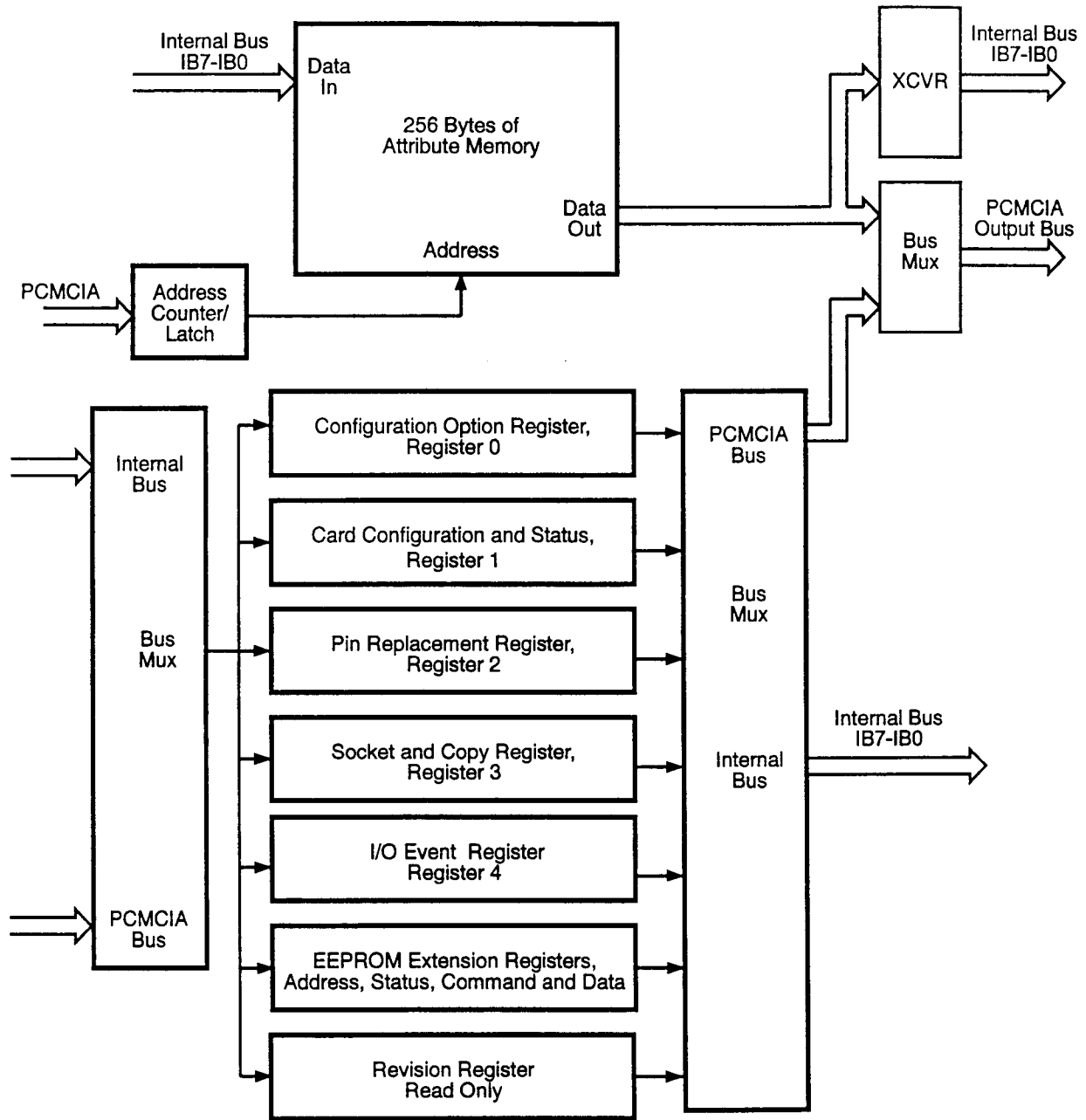

Attribute and Configuration Memory Diagram

**PIN DESCRIPTION**

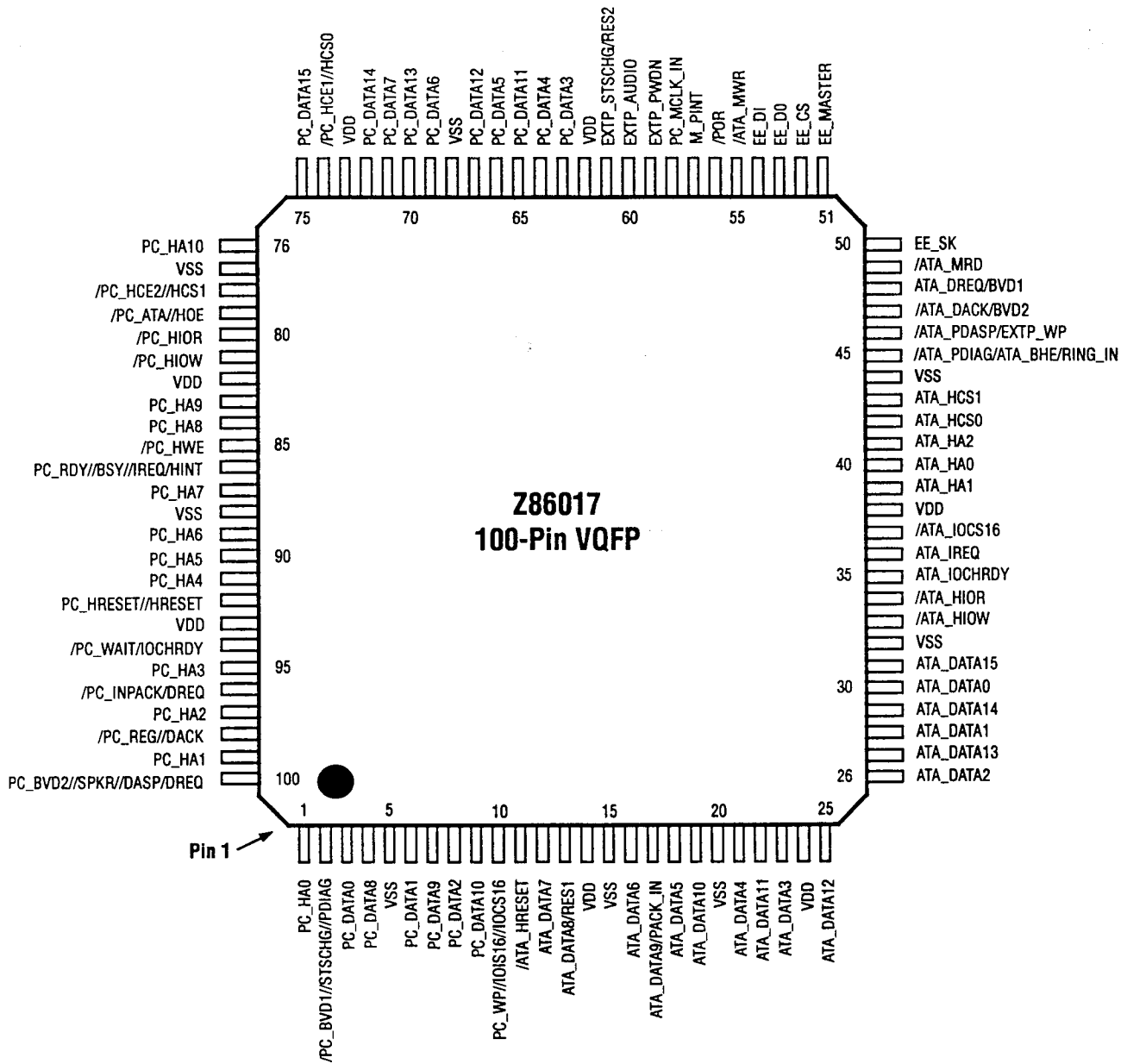

**Z8601720ASC 100-Pin VQFP Package**



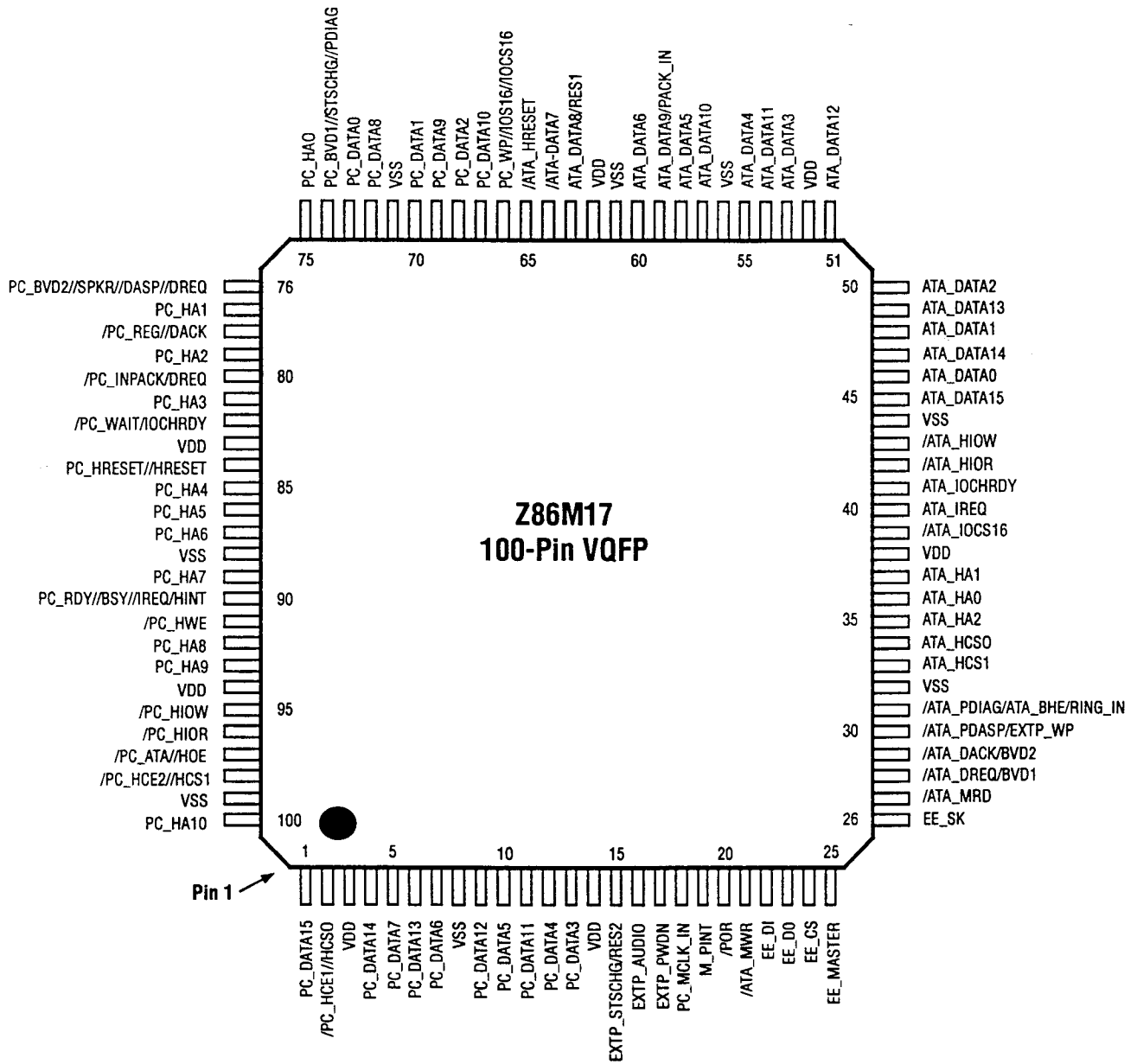

**Z86M1720ASC 100-Pin VQFP Package**

## ABSOLUTE MAXIMUM RATINGS

Symbol	Description	Min	Max	Unit
$V_{CC}$	Supply Voltage*	-0.3	+7.0	V
$T_{STG}$	Storage Temp.	-65	+150	C
$T_A$	Oper. Ambient Temp.	0°	+70°	C

\* Voltages on all pins with respect to GND.

Stresses greater than those listed under Absolute Maximum Ratings may cause permanent damage to the device. This is a stress rating only; operation of the device at any condition above those indicated in the operational sections of these specifications is not implied. Exposure to absolute maximum rating conditions for an extended period may affect device reliability.

## STANDARD TEST CONDITIONS

The characteristics listed below apply for standard test conditions as noted (Test Load Diagram).

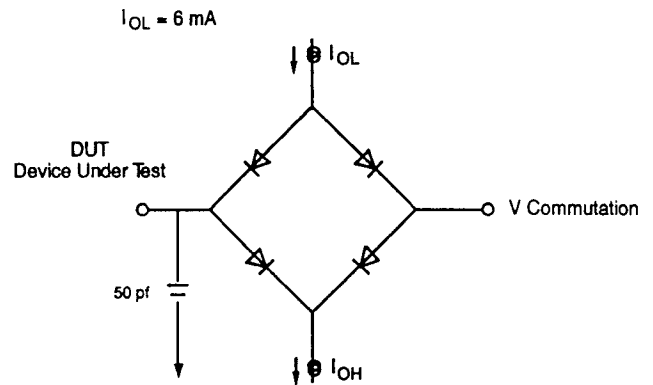

**Test Load Diagram**

## DC SPECIFICATIONS

### Absolute Maximum Ratings

Parameter	Symbol	Unit	Min Value	Max Value
Supply Voltage	$V_{DD}$	V	-0.5	7.0
Input Voltage	$V_I$	V	-0.5	$V_{DD} + 0.5$
Output Voltage	$V_O$	V	-0.5	$V_{DD} + 0.5$
Storage Temperature	$T_{STG}$	C	-40	+125
Temperature Under Bias	$T_{BIAS}$	C	-25	+85

### 5.0V Operating Conditions

Parameter	Symbol	Unit	Min Value	Typical	Max Value
Supply Voltage	$V_{DD}$	V	4.5		5.5
Input High Voltage for TTL Inputs	$V_{IH}$	V	2.4		$V_{DD}$
Input Low Voltage for TTL Inputs	$V_{IL}$	V	-0.5		0.8
*Input Low Voltage for Schmitt-Triggered Inputs	$V_{IL}$	V	-0.5	0.8	
Operating Temperature	$T_A$	°C	0		70

\* Schmitt-Triggered Inputs - PC\_HRESET//HRESET, /POR, PC\_MCLK\_IN

## DC ELECTRICAL CHARACTERISTICS

Parameter	Symbol	Unit	Min Value	Max Value
Power Supply Current (1)	$I_{DDs}$	mA		5 (@ 5V)
Output High Voltage	$V_{OH}$ ( $I_{OH} = -6$ mA)	V	2.4	$V_{DD}$
Output Low Voltage	$V_{OL}$ ( $I_{OL} = 6$ mA)	V		0.4
Input Leakage Current	$I_L$ $V_I \leq V_{DD}$	μA	-10	10
Power Dissipation	$P_{MAX}$	mW		25 @ 5V
	Power Down Mode (2)	mW		2.5 @ 5V
Input Capacitance	$C_I$	pF		8 pF

#### Note:

(1) Inputs driven to 0V outputs floating PC\_MCLK\_IN=20 MHz, EE\_SK=0

(2) EN\_PADs bit set and PC\_MCLK\_IN = 0, EE\_SK = 0

### INTERNAL ATTRIBUTE MEMORY TIMING

(Speed Version: 300 ns)

No	Symbol	Parameter	Min	Max	Units
1	TcR	Read Cycle Time	300		ns
2	TaA	Address Access Time		300	ns
3	TaCE	Card Enable Time		300	ns
4	TaOE	Output Enable Access Time		150	ns
5	TdisCE	Output Disable Time from CE		100	ns
6	TdisOE	Output Disable Time from OE		100	ns
7	TenCE	Output Enable Time from CE	5		ns
8	TenOE	Output Enable Time from OE	5		ns
9	TvA	Data Valid from Address Change	0		ns
10	TsuA	Address Setup Time	30		ns
11	ThA	Address Hold Time	20		ns
12	TsuCE	Card Enable Setup Time	0		ns
13	ThCE	Card Enable Hold Time	20		ns
14	TvWToe	Wait Valid from OE		35	ns
15	TwWT	Wait Pulse Width		12	µs
16	TvWT	Data Setup for Wait Released	0		ns

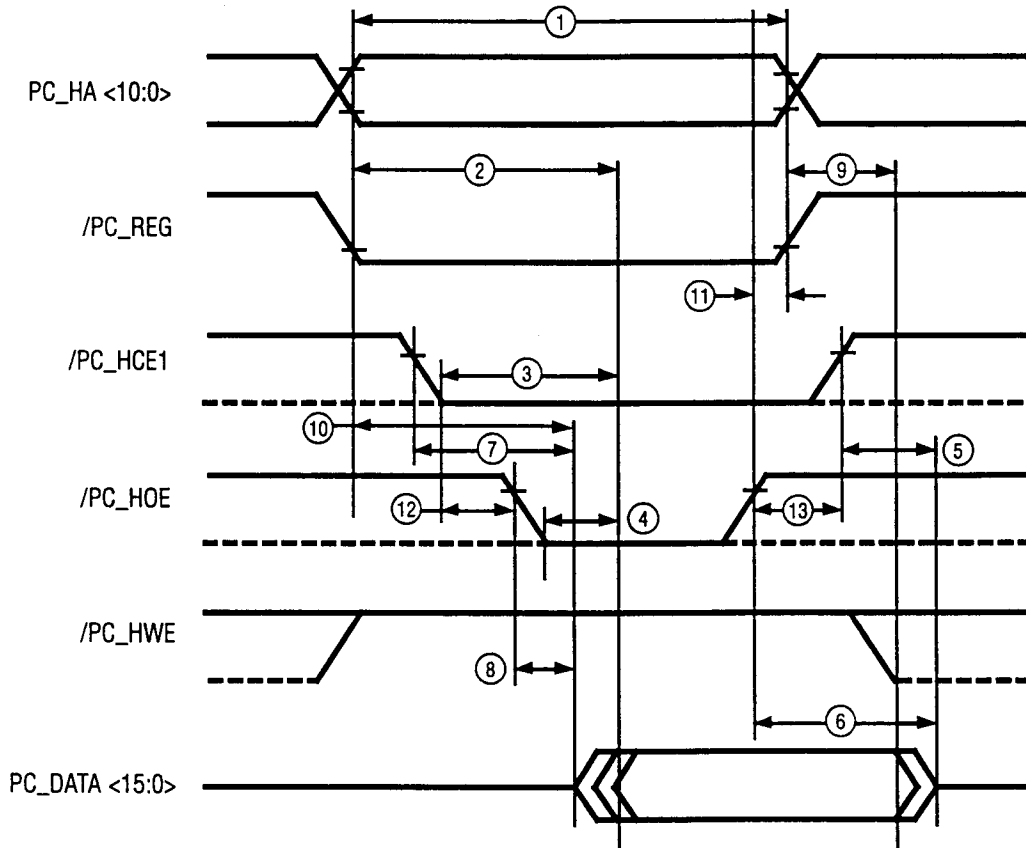

**Note:** /PC\_REG is active Low for Attribute Memory reads only.

#### PCMCIA Read Memory Timing, No Wait States

THIS PAGE IS NOT AVAILABLE

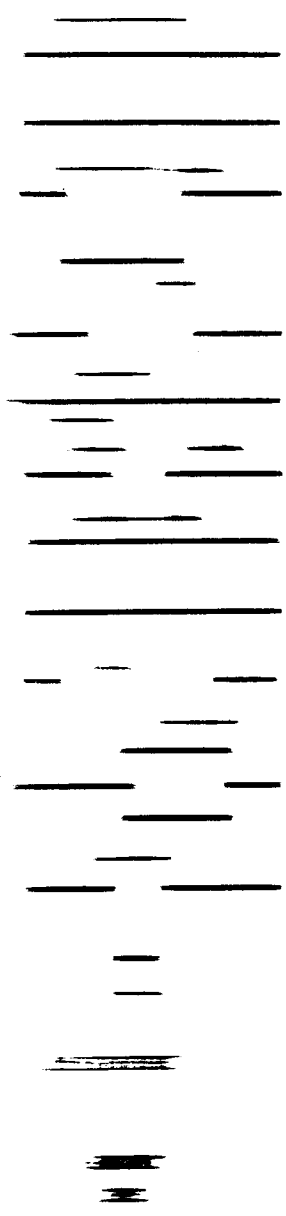

THIS PAGE IS NOT AVAILABLE

## PCMCIA MEMORY WRITE TIMING

No	Symbol	Parameter	200 ns		150 ns		100 ns		Units
			Min	Max	Min	Max	Min	Max	
17	TcW	Write Cycle Time	200		150		100		ns
18	TwWE	Write Pulse Width	120		80		60		ns
19	TsuA	Address Setup Time	20		20		10		ns
20	TsuAwe	Address Setup Time for WE	140		100		70		ns
21	TsuCwe	Card Enable Setup Time for WE	140		100		70		ns
22	TsuDwe	Data Setup Time for WE	60		50		40		ns
23	ThD	Data Hold Time	30		20		15		ns
24	TrecWE	Write Recover Time	30		20		15		ns
25	TdisOwe	Output Disable Time from WE		90		75		50	ns
26	TdisOE	Output Disable Time from OE		90		75		50	ns
27	TenWE	Output Enable Time from WE	5		5		5		ns
28	TsuCwe	Output Enable Setup from WE	10		10		10		ns
29	ThCwe	Card Enable Hold from WE	10		10		10		ns
30	TsuCE	Card Enable Setup Time	0		0		0		ns
31	ThCE	Card Enable Hold Time	20		20		15		ns
32	TvWTwe	Wait Valid from WE		35		35		35	ns
33	TwWT	Wait Pulse Width		12		12		12	μs
34	TvWT	WE High from Wait Released	0		0		0		ns

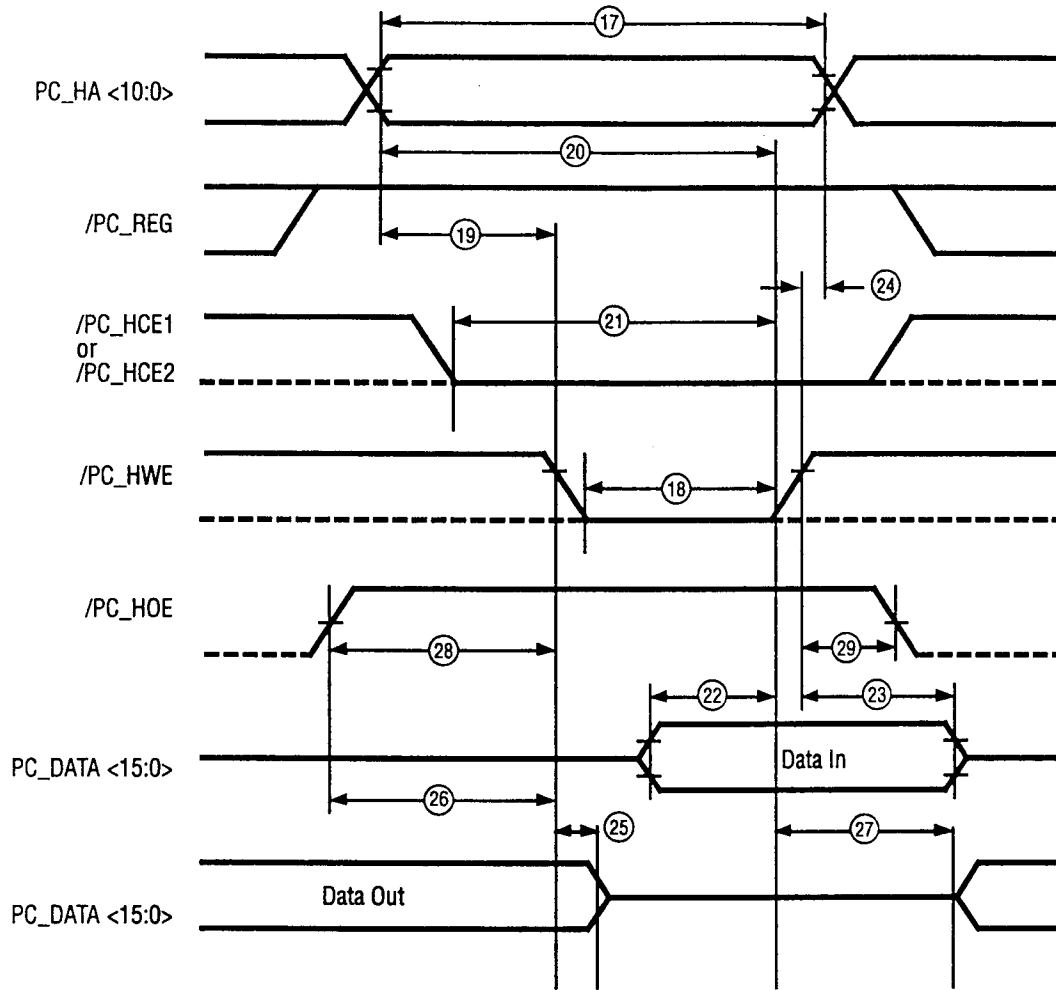

**Note:** PC\_REG is active Low for Attribute Memory reads only.

**PCMCIA Write Memory Timing,  
No Wait States**

PCMCIA MEMORY WRITE TIMING (Continued)

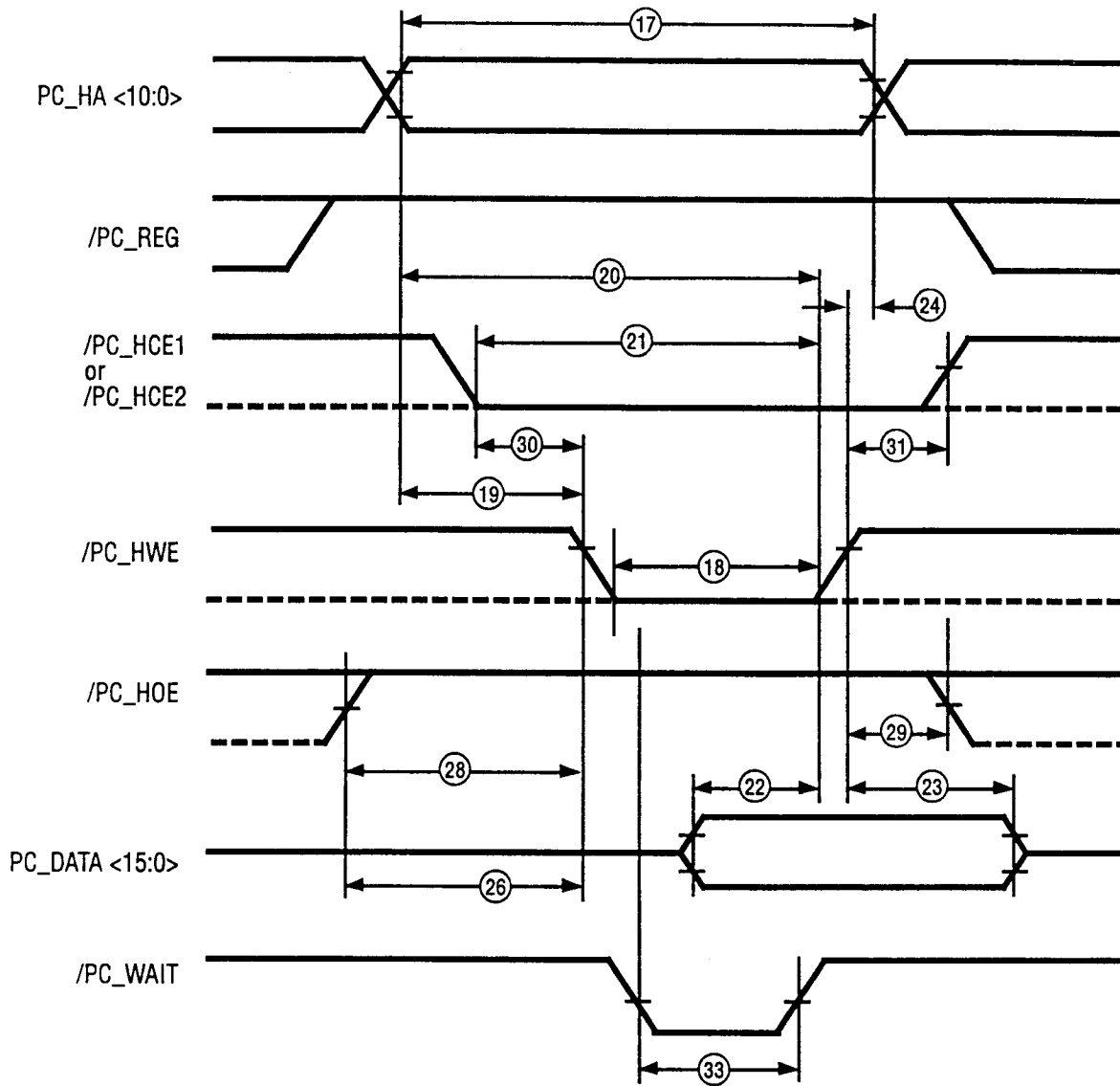

**Note:** /PC\_REG is active Low for Attribute Memory reads only.

PCMCIA Write Memory Timing,  
Wait State Enabled



## I/O READ TIMING SPECIFICATION

No	Symbol	Parameter	Min	Max	Units
35	TdIORD	Data Delay After IORD	100		ns
36	ThIORD	Data Hold Following IORD	0		ns
37	twIORD	IORD Width Time	165		ns
38	TsuAiord	Address Setup Before IORD	70		ns
39	ThAiord	Address Hold Following IORD	20		ns
40	TsuCEiord	CE Setup Before IORD	5		ns
41	ThCEiord	CE Hold Following IORD	20		ns
42	TsuRgiord	REG Setup before IORD	5		ns
43	ThRgiord	REG Hold Following IORD	0		ns
44	TdIPkiord	INPACK Delay to IORD	0	45	ns
45	TdIPkiord	INPACK Delay from IORD		45	ns
46	TdIOISad	IOIS16 Delay from Address		35	ns
47	TdIOISadr	IOIS16 Delay Rise from Address		35	ns
48	TdWiord	Wait Delay from IORD		35	ns
49	TdWTr	Data Delay from Wait Rising		35	ns
50	TwWT	Wait Width Time		12	μs

PCMCIA MEMORY WRITE TIMING (Continued)

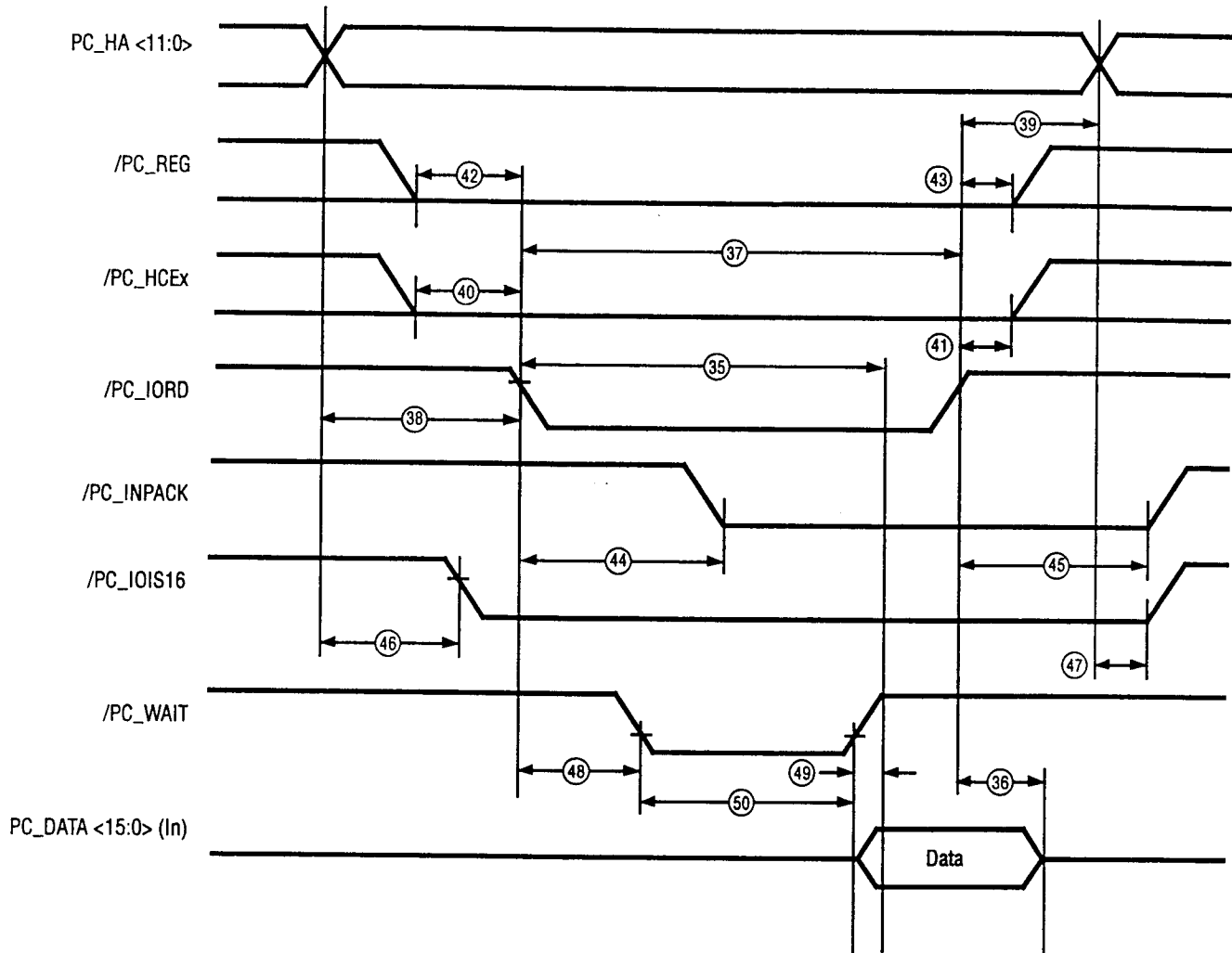

I/O Read Timing

**I/O WRITE TIMING SPECIFICATION**

No	Symbol	Parameter	Min	Max	Units
51	TsuIOWR	Data Setup before IOWR	60		ns
52	ThIOWR	Data Hold after IOWR	30		ns
53	TwIOWR	IOWR Width Time	165		ns
54	TsuAiowr	Address Setup to IOWR	70		ns
55	ThAiowr	Address Hold after IOWR	20		ns
56	TsuCEiowr	CE Setup before IOWR	5		ns
57	ThCEiowr	CE Hold after IOWR	20		ns
58	TsuRGiowr	REG Setup before IOWR	5		ns
59	ThRGiowr	REG Hold after IOWR	0		ns
60	TdIOISadr	IOIS16 Delay Falling from Address		35	ns
61	TIdIOISadr	IOIS16 delay Rising from Address		35	ns
62	TdWTiowr	Wait Delay Falling from IOWR		35	ns
63	TwWT	Wait Width Timing		12	$\mu$ s

I/O WRITE TIMING SPECIFICATION (Continued)

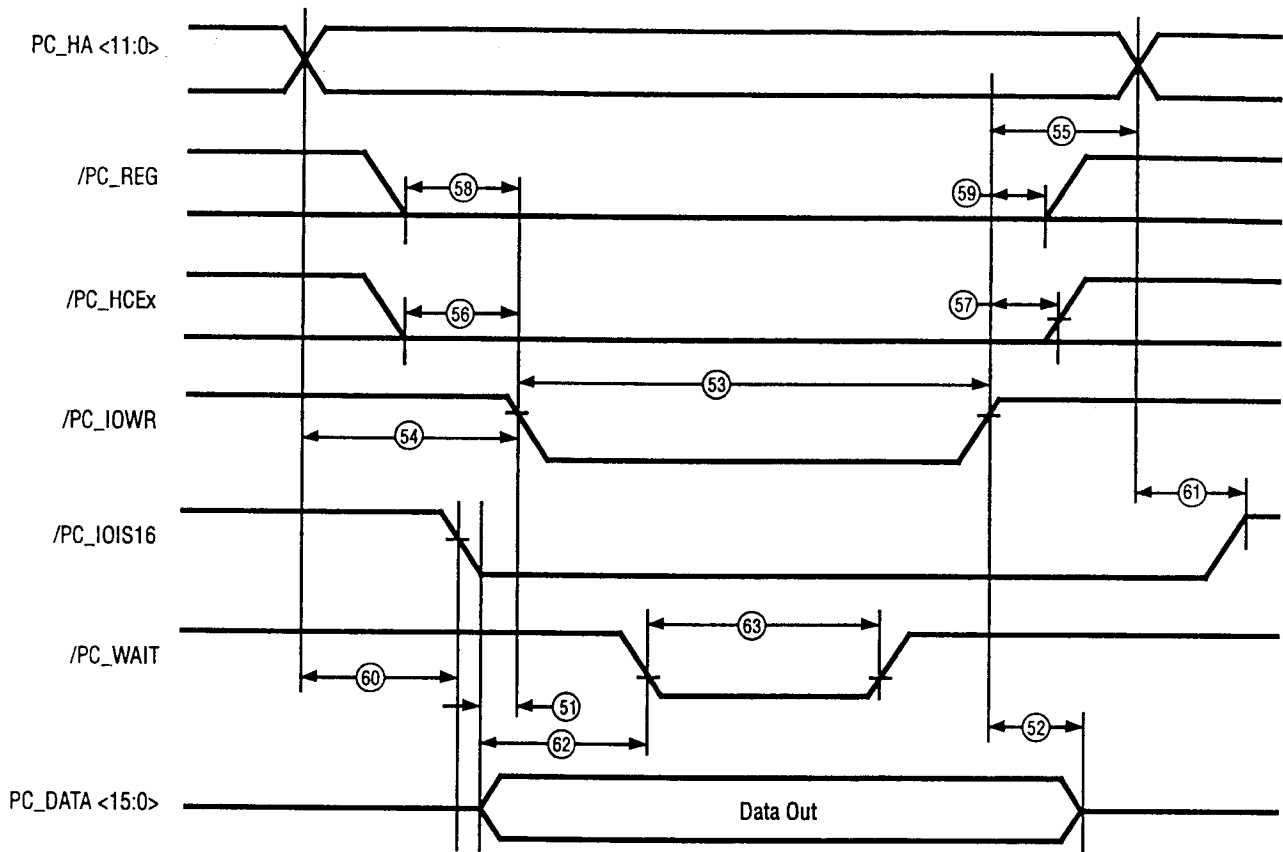

I/O Write Timing

Z86017BA DEVICE

SKEW Timing Between PCMCIA and ATA/IDE Or Peripheral Bus

No	Symbol	Parameter	Min	Max	Units
64	TskADR	Address Skew		25	ns
65	TskI/Of	I/O Fall Skew		25	ns
66	TskI/Or	I/O Rise Skew		25	ns
67	TskMEMf	Mem Fall Skew		25	ns
68	TskMEMr	Mem Rise Skew		25	ns

50 pF Load

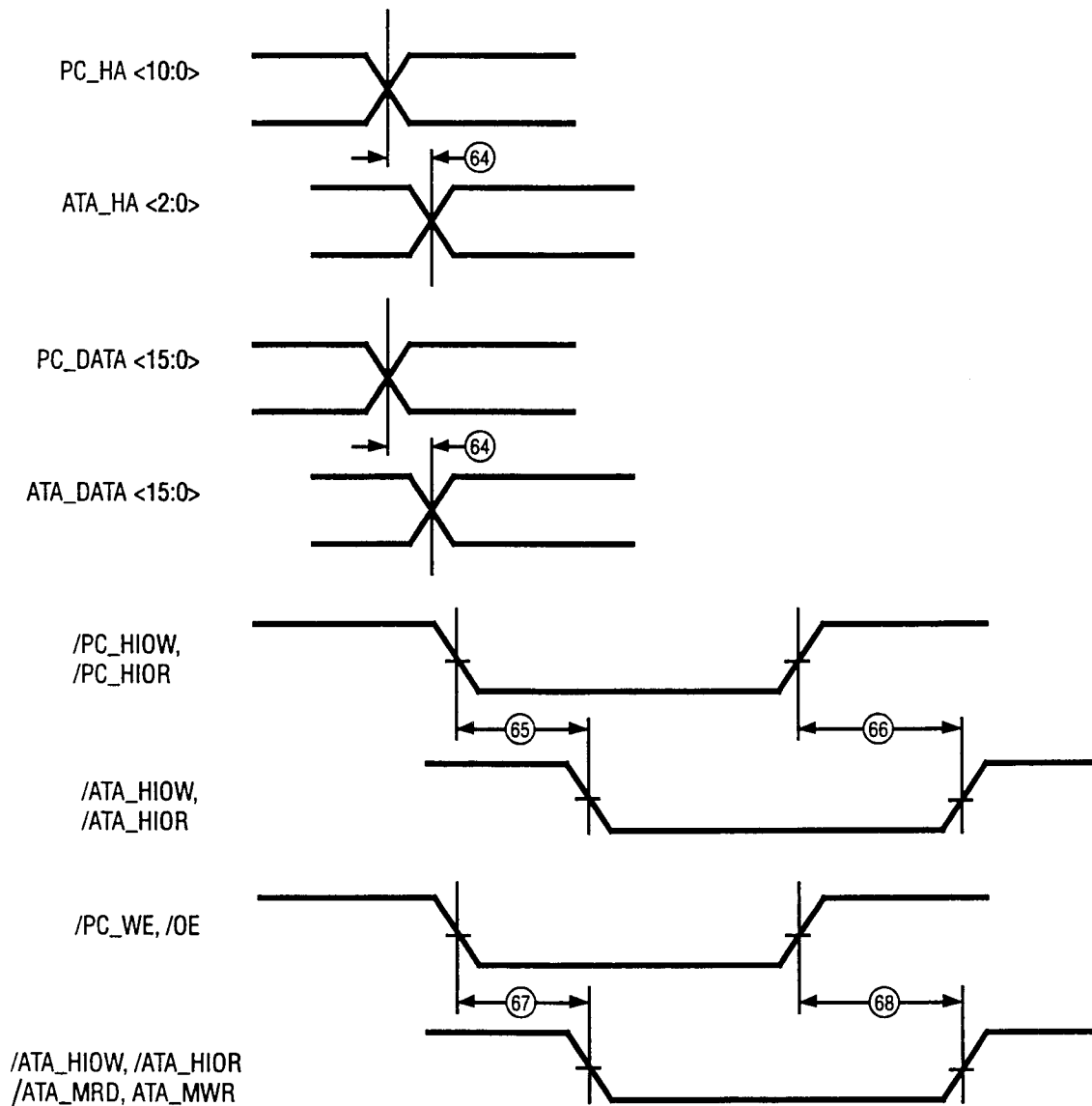

SKEW Timing Between PCMCIA and ATA/IDE or Peripheral Bus

## Z86017BA DEVICE (Continued)

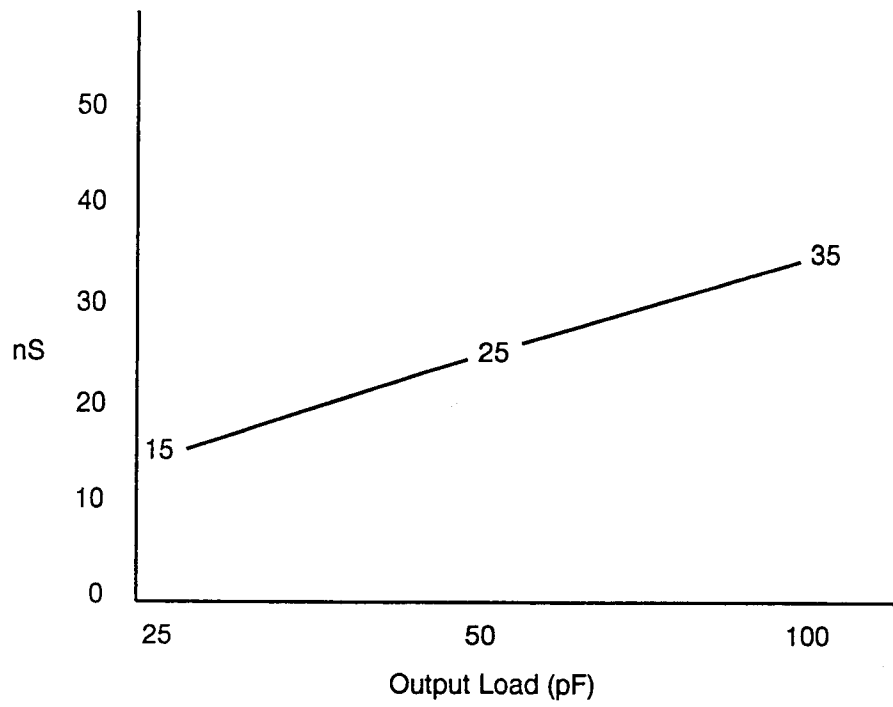

Z86017BA Slew Delay Derating Curve (Typical)

SERIAL INTERFACE TIMING

No	Symbol	Parameter	Min	Max	Units
69	TpMCKin	Master Clock In Period	50		ns
70	TsuCS	CS Setup to CLK time	25		ns
71	ThCS	CS Hold after CLK	0		ns
72	ThDout	Data Hold Time	10		ns
73	TsuDout	Data Setup Time	25		ns
74	ThDin	Data Hold Time	0		ns
75	TsuDin	Data Setup Time	25		ns
76	TpCKw	Clock Period, Master	200		ns
77	TpCKs	Clock Period, Slave	200		ns

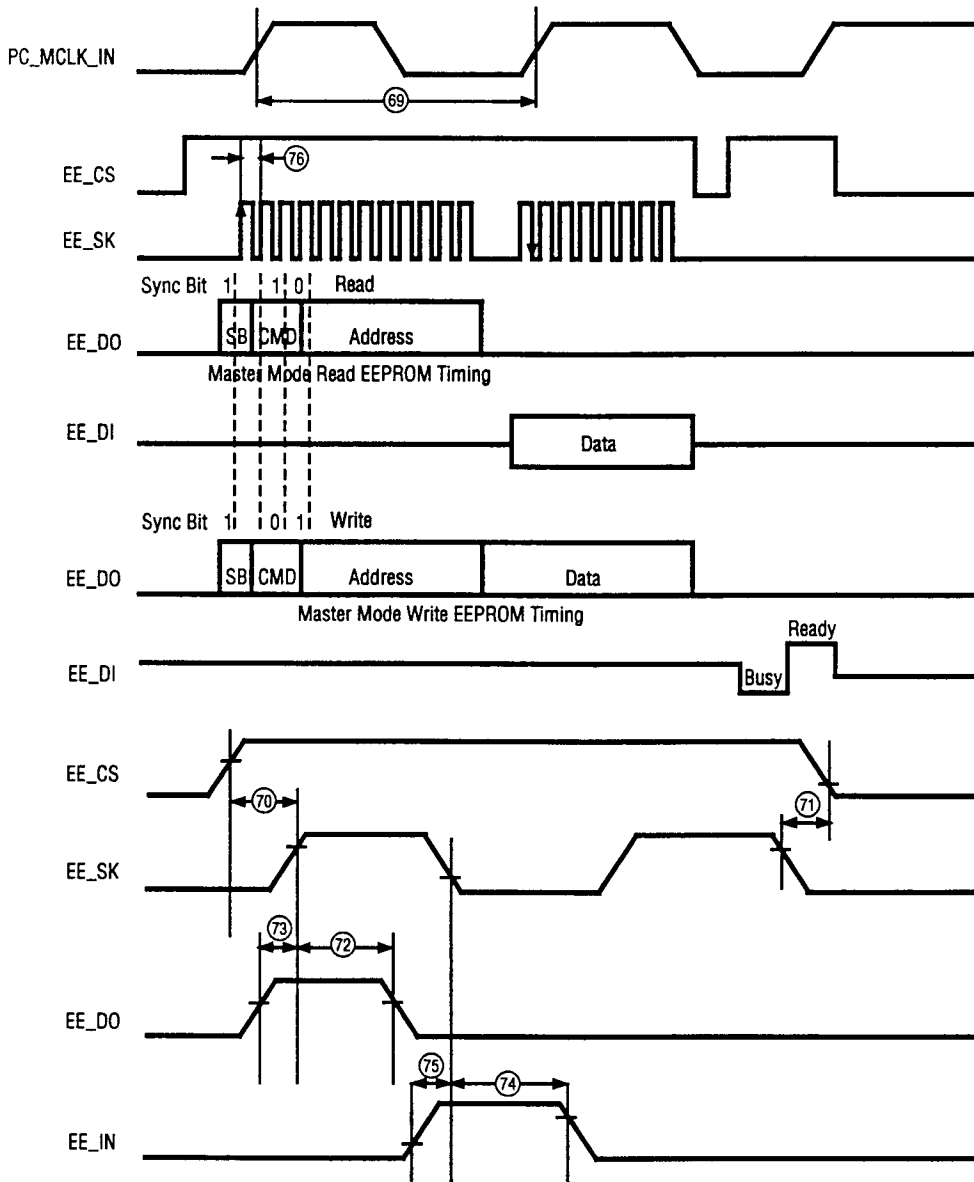

Master Mode Read EEPROM Timing

SERIAL INTERFACE TIMING (Continued)

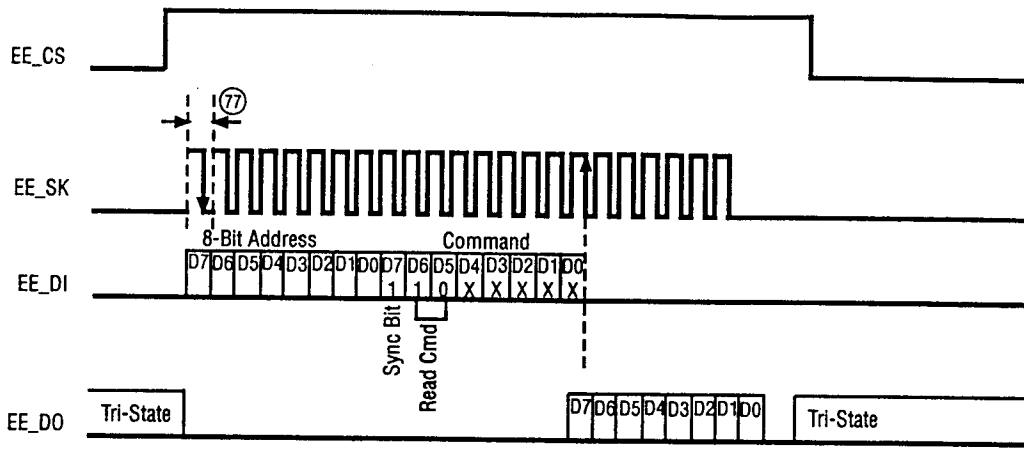

Slave Read Command

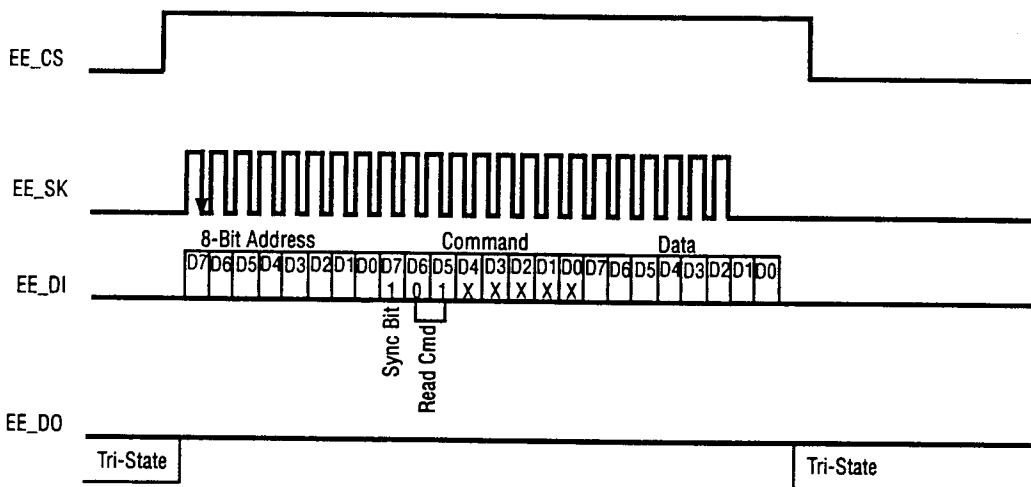

Slave Write Command

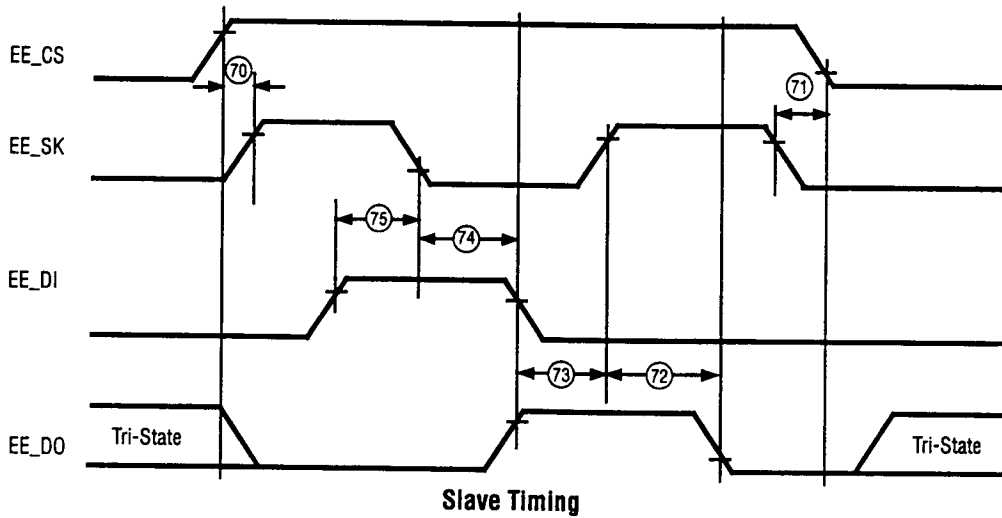

Slave Interface Timing (Read)



**Z86017/Z86M17 OPERATING ERRATA**

- 1) When the "EN\_PADs" bit is set in register 2BH access to the CCR registers are disabled. Access to common memory and I/O space is still functional.
- 2) Setting the soft reset bit in the configuration option register will not be cleared out by a hardware host reset (PC\_HRESET).

---

**Standard Product:**

Product acknowledged by Zilog to ship within thirty (30) days cannot be cancelled or rescheduled. This order will

be invoiced for the full amount for all product cancelled or rescheduled within the thirty (30) days of the scheduled ship date.

---

**Pre-Characterization Product:**

The product represented by this CPS is newly introduced and Zilog has not completed the full characterization of the product. The CPS states what Zilog knows about this product at this time, but additional features or non-con-

formance with some aspects of the CPS may be found, either by Zilog or its customers in the course of further application and characterization work. In addition, Zilog cautions that delivery may be uncertain at times, due to start-up yield issues.

---

**Low Margin:**

Customer is advised that this product does not meet Zilog's internal guardbanded test policies for the specification requested and is supplied on an exception basis. Customer is cautioned that delivery may be uncertain and that, in addition to all other limitations on Zilog liability

stated on the front and back of the acknowledgement, Zilog makes no claim as to quality and reliability under the CPS. The product remains subject to standard warranty for replacement due to defects in materials and workmanship.

---

© 1996 by Zilog, Inc. All rights reserved. No part of this document may be copied or reproduced in any form or by any means without the prior written consent of Zilog, Inc. The information in this document is subject to change without notice. Devices sold by Zilog, Inc. are covered by warranty and patent indemnification provisions appearing in Zilog, Inc. Terms and Conditions of Sale only. Zilog, Inc. makes no warranty, express, statutory, implied or by description, regarding the information set forth herein or regarding the freedom of the described devices from intellectual property infringement. Zilog, Inc. makes no warranty of merchantability or fitness for any purpose. Zilog, Inc. shall not be responsible for any errors that may appear in this document. Zilog, Inc. makes no commitment to update or keep current the information contained in this document.

Zilog's products are not authorized for use as critical components in life support devices or systems unless a specific written agreement pertaining to such intended use is executed between the customer and Zilog prior to use. Life support devices or systems are those which are intended for surgical implantation into the body, or which sustains life whose failure to perform, when properly used in accordance with instructions for use provided in the labeling, can be reasonably expected to result in significant injury to the user.

Zilog, Inc. 210 East Hacienda Ave.  
Campbell, CA 95008-6600  
Telephone (408) 370-8000  
Telex 910-338-7621

## X-ON Electronics

Largest Supplier of Electrical and Electronic Components

*Click to view similar products for [Interface - Specialized category](#):*

*Click to view products by [ZiLOG manufacturer](#):*

Other Similar products are found below :

[CY7C910-51LMB](#) [MC33689DPEWR2](#) [MC33975TEKR2](#) [MEC1632-AUE](#) [MC33978AEK](#) [NVT4555UKZ](#) [TJA1081TS,112](#) [RKSAS4](#)  
[HMC677G32](#) [LPC47N207-JV](#) [FTP-637DSL633R](#) [MAX7348AEP+](#) [SM712GX04LF04-BA](#) [DS2413P+T&R](#) [NCN5193MNTWG](#)  
[MC34978AEK](#) [MC33689DPEW](#) [MC33889BPEG](#) [NCV7381DP0R2G](#) [PCA9704PWJ](#) [S6BT112A01SSBB202](#) [MAX7347AEE+](#) [DS8113-](#)  
[RNG+T&R](#) [DS8024-RJX+T&R](#) [NCN5192MNRG](#) [DS8023-RRX+T&R](#) [DS8024-RRX+T&R](#) [ST8034HCQR](#) [XP71055](#)  
[TC7PCI3212MT,LF\(S](#) [ASI4UE-F-G1-ST](#) [HOA6241-001](#) [MEC1310-NU](#) [SC74HC4066ADTR2G](#) [TDA8035HNC1S1QL](#) [TNY380PN](#)  
[RMT3PB080](#) [AS3935-BQFT](#) [0714300268](#) [MAX9924UAUB/V+](#) [MAX3120CUA+](#) [MAX3171CAI](#) [NCN8025MTTBG](#) [DS8023-RRX](#)  
[DS2406P+T&R](#) [DS8007-ENG+](#) [DS8007A-EAG+](#) [DS2482X-101T](#) [DS1886T+](#) [DG407AK/883B](#)