



**Z8 Encore! XP<sup>®</sup> Microcontroller**

**Z8 Encore! XP<sup>®</sup> F042A Series  
8-Pin Development Kit**

**User Manual**

UM018705-0508

## Revision History

Each instance in Revision History reflects a change to this document from its previous revision. For more details, refer to the corresponding pages and appropriate links in the table below.

Date	Revision Level	Description	Page No
May 2008	05	Updated <a href="#">Introduction</a> and <a href="#">Table 1</a> .	<a href="#">1</a> and <a href="#">8</a>
March 2008	04	Changed title to Z8 Encore! XP F042A Series 8-Pin Development Kit. Updated <a href="#">System Requirements</a> , <a href="#">Installation</a> , <a href="#">Documentation</a> , and <a href="#">Use of Ceramic Resonator Y1</a> sections. Added <a href="#">Zilog Help Options</a> section.	All
February 2008	03	Updated new Zilog logo, implemented Style guide, and changed ZiLOG to Zilog.	All
May 2005	02	Updated <a href="#">Figure 1</a> and <a href="#">Figure 2</a> .	<a href="#">2</a> and <a href="#">5</a>
January 2005	01	Original Issue.	All



# Table of Contents

<b>Introduction</b> .....	<b>1</b>
Kit Contents .....	1
Hardware .....	1
Software (on CD-ROM) .....	2
Documentation .....	3
System Requirements .....	3
Designing with the USB Smart Cable .....	4
Installation .....	4
<b>Development Board</b> .....	<b>5</b>
Introduction .....	5
Features .....	6
MCU .....	6
UART with IrDA ENDEC .....	7
Jumpers and Settings .....	8
DEMO Mode Jumper Settings .....	10
USER DEBUG Mode Jumper Settings .....	10
Switches S1, S2, and SW1 .....	10
External Interface Headers JP1 and JP2 .....	11
Use of Ceramic Resonator Y1 .....	11
Zilog Help Options .....	11
<b>Schematics</b> .....	<b>12</b>
<b>Customer Support</b> .....	<b>14</b>

# Introduction

Zilog's Z8 Encore! XP<sup>®</sup> F042A Series 8-pin microcontroller unit (MCU) is part of the Zilog MCU products. The Z8 Encore! XP F042A Series 8-Pin development kit (Z8F04A08100KITG) enables you to become familiar with the hardware and software tools available with this product. This kit consists of 4 KB version of the Z8 Encore! development board that supports and presents the features of the Z8 Encore! XP F042A Series 8-pin package. This kit allows you to write application software and contains all supporting documents. Z8F042ASB020 is the silicon used in the board. For more information, refer to *Z8 Encore! XP<sup>®</sup> F082A Series Product Specification (PS0228)*.

This user manual acquaints you with the Z8 Encore! XP F042A Series 8-pin MCU development kit, and gives instructions on setting up and using the tools to start building designs and applications.

## Kit Contents

The Z8 Encore! XP F042A Series 8-Pin MCU development kit contains the following:

### Hardware

The hardware components include:

- Z8 Encore! XP F042A Series 8-pin development board
- USB Smart Cable for PC to Z8 Encore! XP F042A Series 8-pin development board
- 5 V DC power supply



**Figure 1. Z8 Encore! XP F042A Series 8-Pin Development Kit Contents (Printed Quick Start Guide Not Shown)**

### **Software (on CD-ROM)**

The software components include:

- ZDS II—Z8 Encore!<sup>®</sup> IDE with ANSI C-Compiler
- Sample code
- Document browser
- Acrobat Reader

## Documentation

The documentation includes:

- Quick Start Guide (QS0055)
- Z8 Encore! XP F042A Series 8-pin technical documentation (on CD-ROM)
  - Development Kit User Manual
  - ZDS II—IDE User Manual (UM0130)
  - eZ8<sup>™</sup> CPU User Manual (UM0128)
  - Application Notes

The sample code is installed with ZDS II and is located at <installation directory>\samples in the disk drive.

The documentation can be installed with the **DemoShield** interface or can be viewed on the CD-ROM using the **DemoShield** menus and a PDF reader. A copy of the acrobat installer is provided on the CD-ROM and can be installed from the **DemoShield** install screen. After installing the documentation on the system Windows Explorer can be used to select any document to be viewed with the PDF file viewer.

## System Requirements

IBM PC (or compatible computer) with the following minimum configurations is required:

- Microsoft Windows XP Professional SP1/Windows 2000 SP3/Windows 98 SE
- Pentium II/233 MHz processor or higher up to Pentium IV, 2.8 GHz
- 96 MB RAM or more
- 35 MB hard disk space or more
- Super VGA video adapter

- CD-ROM
- One USB high-speed or full-speed port on the host chassis or a powered Hub

### Designing with the USB Smart Cable

Z8 Encore! XP<sup>®</sup> F042A Series 8-pin development kit uses the USB Smart Cable provided in the kit. The Z8 Encore! Serial Smart Cable and associated TIM will not work with the Z8F04A08100KITG kit. Include the following when designing the target board and application:

- The target design's debug interface must include a RESET pin.
- The target application must allow the RESET pin to be pulled LOW.

For more details, refer to *Z8 Encore! XP<sup>®</sup> F082A Series Product Specification (PS0228)*.

### Installation

For details on software installation and setup of the Z8 Encore! XP F042A Series 8-pin development kit refer to *Z8 Encore! XP<sup>®</sup> F042A 8-Pin Development Kit Quick Start Guide (QS0055)*.

# Development Board

## Introduction

Z8 Encore! XP® F042A Series 8-pin development board is a development and prototyping board for the Z8 Encore! XP F042A Series 8-pin MCU. The board provides a tool to evaluate features of Z8 Encore! XP F042A Series 8-pin MCU, and to start developing an application before building the hardware.

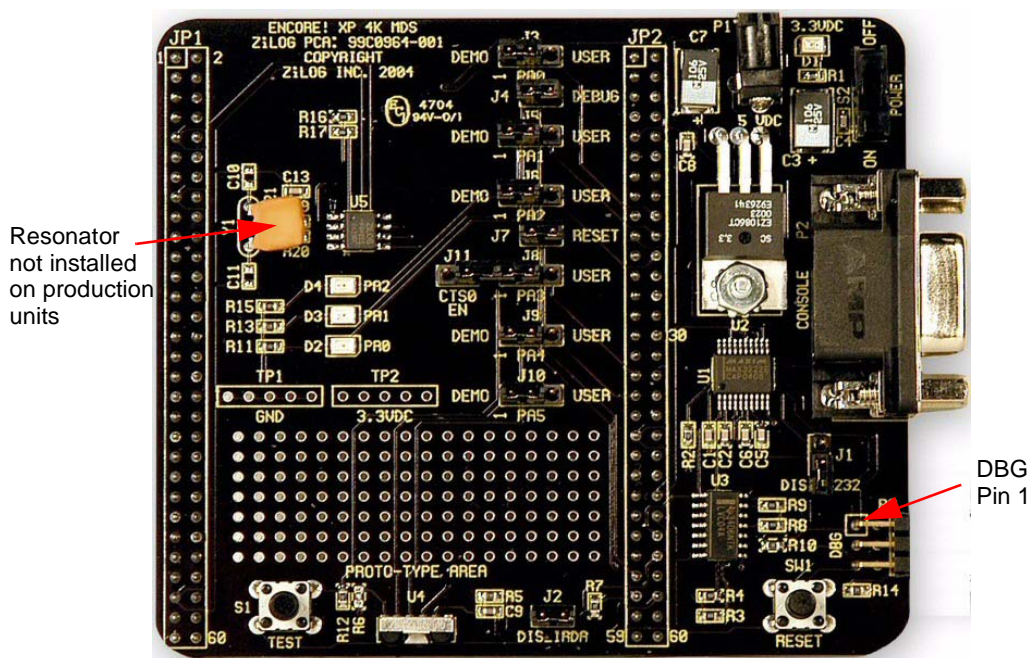

Figure 2. Z8 Encore! XP F042A Series 8-Pin Development Board



## Features

The features of Z8 Encore! XP<sup>®</sup> F042A Series 8-pin development board include:

- Z8 Encore!<sup>®</sup> MCU (8-pin SOIC)
- 3 LEDs
- RS-232 interface
- IrDA transceiver
- Two pushbuttons: RESET and TEST
- 5 V DC power connector
- On-Chip Debugger interface
- Prototyping area
- External interface connectors JP1 and JP2
- 2.7 V–3.6 V operating voltage with 5 V-tolerant inputs

## MCU

Z8 Encore! XP F042A Series 8-pin MCU is member of a family of Zilog<sup>®</sup> MCU products based upon the 8-bit eZ8<sup>™</sup> core CPU. The Flash in-circuit programming capability allows for faster development time and program changes in the field. The eZ8 core CPU is upward compatible with existing Z8<sup>®</sup> instructions. The rich peripheral set of the Z8 Encore! XP F042A Series makes it suitable for a variety of applications including motor control, security systems, home appliances, personal electronic devices, and sensors.

The development board contains circuitry to support and present all the features of the Z8 Encore! XP F042A Series.

The key features of the Z8 Encore! XP<sup>®</sup> F042A Series 8-pin MCU include:

- eZ8<sup>™</sup> core CPU
- 4 KB Flash memory with in-circuit programming capability
- 1 KB register RAM
- 5-channel, 10-bit analog-to-digital converter (ADC)
- Full-duplex UART
- Infrared Data Association (IrDA)-compliant infrared encoder/decoder
- Two 16-bit timers with capture, compare, and PWM capability
- Watchdog Timer (WDT) with internal RC oscillator
- Six I/O pins
- Programmable priority interrupts
- On-Chip Debugger
- Voltage Brownout (VBO) Protection
- Power-On Reset (POR)
- 2.7 V–3.6 V operating voltage with 5 V-tolerant inputs
- Operating temperatures: 20 °C ±10 °C

For more information on the Z8 Encore!<sup>®</sup> family of devices, refer to *Z8 Encore! XP<sup>®</sup> F082A Series Product Specification (PS0228)*, available for download at [www.zilog.com](http://www.zilog.com).

## UART with IrDA ENDEC

Z8 Encore! XP F042A Series 8-pin MCU (component U5) contains a fully-functional, high-performance UART with Infrared Encoder/Decoder (endec). The Infrared endec is integrated with an on-chip UART allowing easy communication between the Z8 Encore! XP F042A Series

8-pin MCU and IrDA transceivers. Infrared communication provides secure, reliable, low-cost, point-to-point communication between PCs, PDAs, cell phones, printers, and other infrared enabled devices.

## Jumpers and Settings

[Table 1](#) lists information on jumper functions.

**Table 1. Z8F04A08100KITG Jumper Functions**

Jumper	State	Description	Default
J1*	OUT	Enables RS-232 interface	X
	IN	Disables RS-232 interface	
J2*	OUT	Enables IrDA interface	
	IN	Disables IrDA interface	X
J3	1-2	Connects U5 pin PA0 to Green LED D2	X
	2-3	Connects U5 pin PA0 to JP2 pin 18	
J4	OUT	Disconnects PA0 from debug (DBG) pin	X
	IN	Connects PA0 to DBG pin 4 on ZDI port P3	
J5	1-2	Connects U5 pin PA1 to yellow LED D3	X
	2-3	Connects U5 pin PA1 to JP2 pin 20	
J6	1-2	Connects U5 pin PA2 to red LED D4	X
	2-3	Connects U5 pin PA2 to JP2 pin 22	

**Table 1. Z8F04A08100KITG Jumper Functions (Continued)**

Jumper	State	Description	Default
J7	OUT	DEMO mode setting	X
	IN	Chip U5 resets when SW1 pressed	
J8	1-2	Connects U5 pin PA3 to J11 pin 1 (CTS0 EN)	X
	2-3	Connects U5 pin PA3 to JP2 pin 35	
J9	1-2	Connects U5 pin PA4 to RXD RS232 signal	X
	2-3	Connects U5 pin PA4 to JP2 pin 35	
J10	1-2	Connects U5 pin PA5 to TXD RS232 signal	X
	2-3	Connects U5 pin PA5 to JP2 pin 36	
J11	OUT	Disconnects PA3 from CTS0 RS232 signal	X
	IN	Connects PA3 to CTS0 RS232 signal	

\*These jumpers must not be OUT at the same time

The board has two modes of operation: DEMO and USER DEBUG. Use DEMO mode to run the sample program included with the kit. Run the board in USER DEBUG mode:

- When using the ZDI port to debug your code.
- When configuring the board to run your own prototype code.

## DEMO Mode Jumper Settings

When running the board in DEMO mode, the following jumpers must be set:

- J3 1-2
- J4 OUT
- J5 1-2
- J6 1-2
- J7 OUT
- J8 1-2
- J9 1-2
- J10 1-2
- J11 OUT

## USER DEBUG Mode Jumper Settings

When running the board in USER DEBUG mode, the following jumpers must be set:

- J3 OUT
- J4 IN
- J6 OUT
- J7 IN

## Switches S1, S2, and SW1

Switches S1, S2, and SW1 on the Z8 Encore! XP<sup>®</sup> F042A Series 8-pin development board perform the following functions:

- S1—Test switch

- S2–Power ON/OFF switch
- SW1–RESET

## External Interface Headers JP1 and JP2

External interface headers JP1 and JP2 are displayed in the [Schematics](#) on page 12.

## Use of Ceramic Resonator Y1

When using ceramic resonator Y1, pins PA0, PA1, and DBG are unavailable. For more information, refer to *Z8 Encore! XP<sup>®</sup> F082A Series Product Specification (PS0228)*.

## Zilog Help Options

Refer to the `readme.txt` and `FAQ.html` included in the ZDS II installation directory; ZDS II On-Line Help and Development Kit User Manuals. For Silicon issues, refer to the related Silicon Product Specification. To locate all documentation included in the kit, refer to the documentation browser located at:

```
<Installation Directory>\ZDSII_Z8Encore!_  
<Version_Number>\Documentation
```

For latest updates on FAQs and to find answers, please contact Customer Support.

# Schematics

Figure 3 and Figure 4 on page 13 display the schematics for Z8 Encore! XP F042A Series

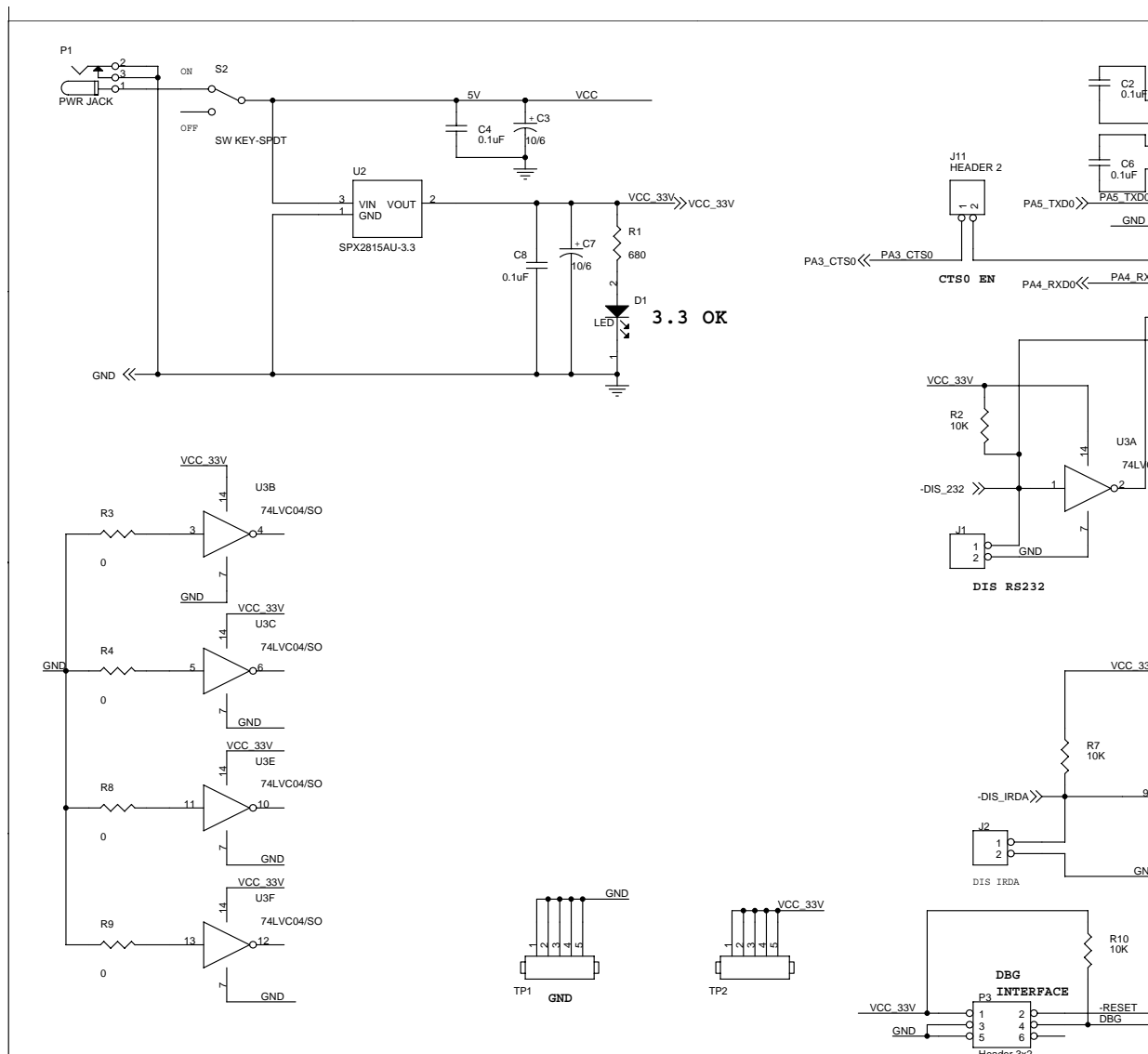

Figure 3. Schematic for Z8 Encore! XP F042A Series 8-Pin MCU D

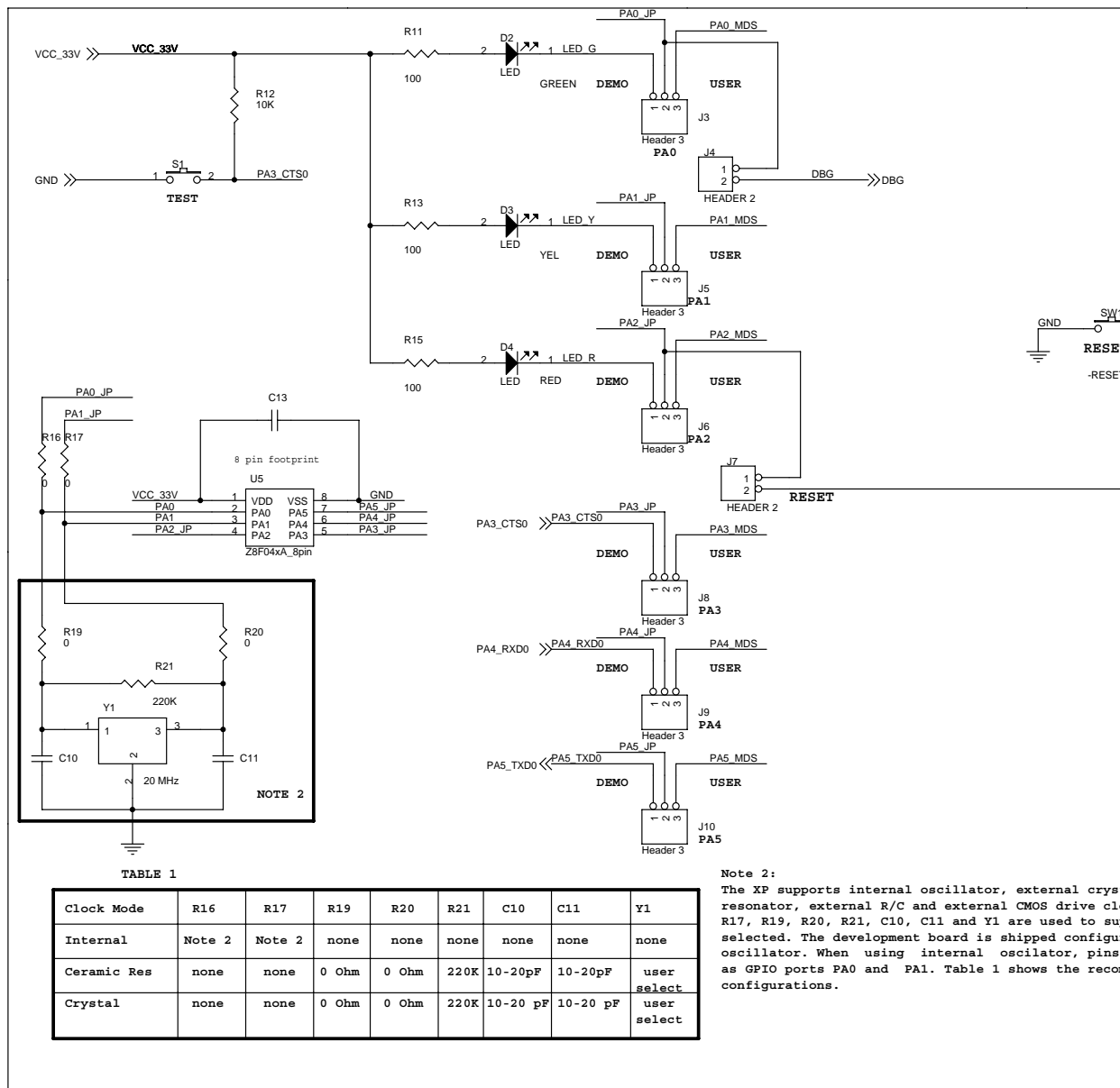

Figure 4. Schematic for Z8 Encore! XP F042A Series 8-Pin MCU D



## Customer Support

For answers to technical questions about the product, documentation, or any other issues with Zilog's offerings, please visit Zilog's Knowledge Base at <http://www.zilog.com/kb>.

For any comments, detail technical questions, or reporting problems, please visit Zilog's Technical Support at <http://support.zilog.com>.



**Warning:** DO NOT USE IN LIFE SUPPORT

### **LIFE SUPPORT POLICY**

ZILOG'S PRODUCTS ARE NOT AUTHORIZED FOR USE AS CRITICAL COMPONENTS IN LIFE SUPPORT DEVICES OR SYSTEMS WITHOUT THE EXPRESS PRIOR WRITTEN APPROVAL OF THE PRESIDENT AND GENERAL COUNSEL OF ZILOG CORPORATION.

### **As used herein**

Life support devices or systems are devices which (a) are intended for surgical implant into the body, or (b) support or sustain life and whose failure to perform when properly used in accordance with instructions for use provided in the labeling can be reasonably expected to result in a significant injury to the user. A critical component is any component in a life support device or system whose failure to perform can be reasonably expected to cause the failure of the life support device or system or to affect its safety or effectiveness.

### **Document Disclaimer**

©2008 by Zilog, Inc. All rights reserved. Information in this publication concerning the devices, applications, or technology described is intended to suggest possible uses and may be superseded. ZILOG, INC. DOES NOT ASSUME LIABILITY FOR OR PROVIDE A REPRESENTATION OF ACCURACY OF THE INFORMATION, DEVICES, OR TECHNOLOGY DESCRIBED IN THIS DOCUMENT. ZILOG ALSO DOES NOT ASSUME LIABILITY FOR INTELLECTUAL PROPERTY INFRINGEMENT RELATED IN ANY MANNER TO USE OF INFORMATION, DEVICES, OR TECHNOLOGY DESCRIBED HEREIN OR OTHERWISE. The information contained within this document has been verified according to the general principles of electrical and mechanical engineering.

Z8, Z8 Encore!, and Z8 Encore! XP are registered trademarks of Zilog, Inc. All other product or service names are the property of their respective owners.

## X-ON Electronics

Largest Supplier of Electrical and Electronic Components

*Click to view similar products for [Development Boards & Kits - Other Processors](#) category:*

*Click to view products by [ZiLOG](#) manufacturer:*

Other Similar products are found below :

[EVB-MEC1418MECC](#) [20-101-1252](#) [CC-ACC-18M433](#) [STM8S/32-D/RAIS](#) [RTK0EN0001D01001BZ](#) [MAXQ622-KIT#](#)  
[YR0K50571MS000BE](#) [QB-R5F104PJ-TB](#) [CC-ACC-ETHMX](#) [OV-7604-C7-EVALUATION-BOARD](#) [SK-AD02-D62Q1747TB](#) [SK-BS01-D62Q1577TB](#) [ST7MDT1-EMU2](#) [GROVE BASE KIT FOR RASPBERRY PI](#) [CY8CKIT-143A](#) [RASPBERRY PI PICO](#) [EK-MPC5744P](#)  
[KITAURIXTC234TFTTOBO1](#) [ENW89854AXKF](#) [ENWF9201AVEF](#) [QB-R5F104LE-TB](#) [LV18F V6 64-80-PIN TQFP MCU CARD EMPTY](#)  
[LV-24-33 V6 44-PIN TQFP MCU CARD EMPTY](#) [LV-24-33 V6 64-PIN TQFP MCU CARD EMPTY](#) [LV-24-33 V6 80-PIN TQFP 1 MCU](#)  
[CARD EMPTY](#) [32X32 RGB LED MATRIX PANEL - 6MM PITCH](#) [3.3 - 5 VTRANSLATOR](#) [READY FOR XMEGA CASING \(WHITE\)](#)  
[RELAY4 BOARD](#) [ETHERNET CONNECTOR](#) [RFID CARD 125KHZ - TAG](#) [RFID READER](#) [RFM12B-DEMO](#) [MAROON](#) [3G CLICK](#)  
[\(FOR EUROPE AND AUSTRALIA\)](#) [MAX232](#) [MAX3232 BOARD](#) [ARTY S7-50](#) [TINKERKIT HALL SENSOR](#) [TOUCHPANEL](#)  
[TOUCHPANEL CONTROLLER](#) [MIKROBOARD FOR AVR WITH ATMEGA128](#) [MIKROBOARD FOR PSOC WITH CY8C27643](#)  
[MIKROBUS CAPE](#) [MIKRODRIVE](#) [MIKROETH 100 BOARD](#) [MIKROLAB FOR 8051 L](#) [MIKROPROG TO ST-LINK V2 ADAPTER](#)  
[BANANA PI GPIO EXTEND MODULE](#) [BATTERY BOOST SHIELD BOARD](#)